



[www.icecompanies.com](http://www.icecompanies.com)  
[www.icerental.com](http://www.icerental.com)



Operator & Parts Manual

Rider Auto Scrubber



**RS26L**  
**RS28L**  
**RS32L**

**i-SYNERGY**  
Cleaning Management in Motion

8300050  
REV.03 (03-2017)

**INTELLIGENT CLEANING EQUIPMENT**



## READ OPERATOR MANUAL CAREFULLY!

**IMPORTANT:** To ensure full warranty protection, please fill out & return your warranty card.

Please fill out at time of installation for future reference.

Model No. \_\_\_\_\_

Serial No. \_\_\_\_\_

Machine Options \_\_\_\_\_

Sales Rep. \_\_\_\_\_

Sales Rep. Phone No. \_\_\_\_\_

Customer ID Number \_\_\_\_\_

Installation Date \_\_\_\_\_

### HOW TO ORDER PARTS

Only use ICE Company supplied or equivalent parts. Parts and supplies may be ordered online, by phone, by fax or by mail.

1. Identify the machine model.
2. Identify the machine serial number from the data label.
3. Ensure the proper serial number is used from the parts list.
4. Identify the part number and quantity.  
Do not order by page or reference numbers.
5. Provide your name, company name, customer ID number, billing and shipping address, phone number and purchase order number.



#### PROTECT THE ENVIRONMENT

Please dispose of packaging materials, old machine components such as batteries, hazardous fluids, including antifreeze and oil, in an environmentally safe way according to local waste disposal regulations.



Always remember to recycle.

### ICE Company Limited

XiangShi Road LiaoBu DongGuan GuangDong China

Tel: 0769 - 81869000

Fax: 0769 - 81863000

Specifications and parts are subject to change without notice.

## TABLE OF CONTENTS

SAFETY PRECAUTIONS.....	4
MACHINE COMPONENTS.....	5-6
MACHINE SETUP & INSTALLATION.....	7
MACHINE OPERATION.....	8
WHILE OPERATING MACHINE.....	9
TANK DRAINING.....	10
BATTERY CHARGING.....	10
PREVENTATIVE MAINTENANCE.....	11
FAULT CODE AND ELIMINATE.....	12
TECHNICAL SPECIFICATION.....	13
PARTS LIST.....	14-39
WEAR AND TEAR PARTS.....	40
WIRING DIAGRAM.....	41

## SAFETY PRECAUTIONS

This machine is intended for commercial use. It is designed exclusively to scrub hard floors in an indoor environment and is not constructed for any other use. Only use recommended accessories.

**All operators shall read, understand and exercise the following safety precautions:**

### 1. Do not operate machine:

- Unless trained and authorized.
- Unless you have read and understand the operators manual.
- In flammable or explosive areas.
- With brake disabled.
- If not in proper operating condition.

### 2. Before starting machine:

- Make sure all safety devices are in place and operate properly.
- Check brakes and steering for proper operation.

### 3. When using machine:

- Go slow on inclines and slippery surfaces.
- Follow all safety guidelines.
- Be very careful when using the machine in reverse.
- Reduce speed when turning.
- Report and fix any damage to machine prior to operating it.
- Never allow children to play on or around.

### 4. Before leaving or servicing machine:

- Stop on level surface.
- Turn off machine.

### 5. When servicing machine:

- Read operators manual thoroughly prior to operating or servicing this machine.
- Use manufacturer supplied or approved replacement parts.
- Secure machine with wheel blocks prior to jacking the machine up.
- Use approved jack or hoist to safely elevate the machine.
- Disconnect batteries prior to working on machine.
- Avoid moving parts. Do not wear loose fitting clothing while servicing machine.

 **WARNING:** Explosion or fire can result from hydrogen gas. Keep sparks and open flames away! Keep battery compartment open when charging.

 **WARNING:** Flammable materials can cause an explosion or fire. Do not use flammable materials in tanks.

 **WARNING:** Flammable materials or reactive metals can cause explosion or fire. Do not pick up.

**MACHINE COMPONENTS**

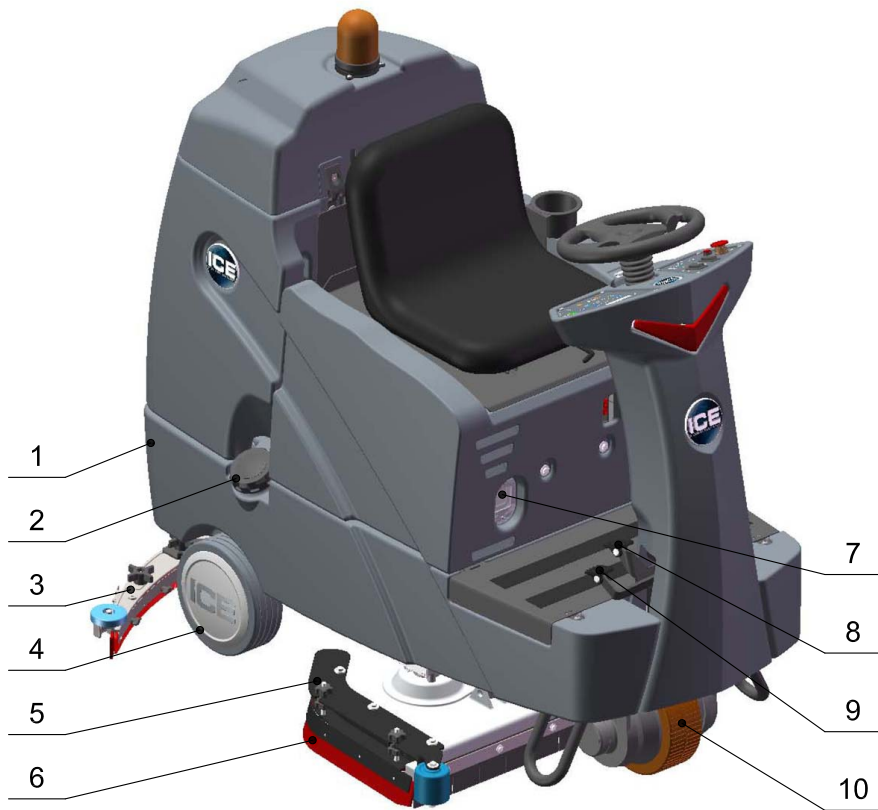

- 1. Solution tank
- 2. Hose fill port & Cap
- 3. Squeegee assembly
- 4. Wheels, 10 inch
- 5. Scrub head assembly
- 6. Side squeegee assembly
- 7. Watching window, on-board battery charger
- 8. Brake pedal
- 9. Propel pedal
- 10. Front drive wheel

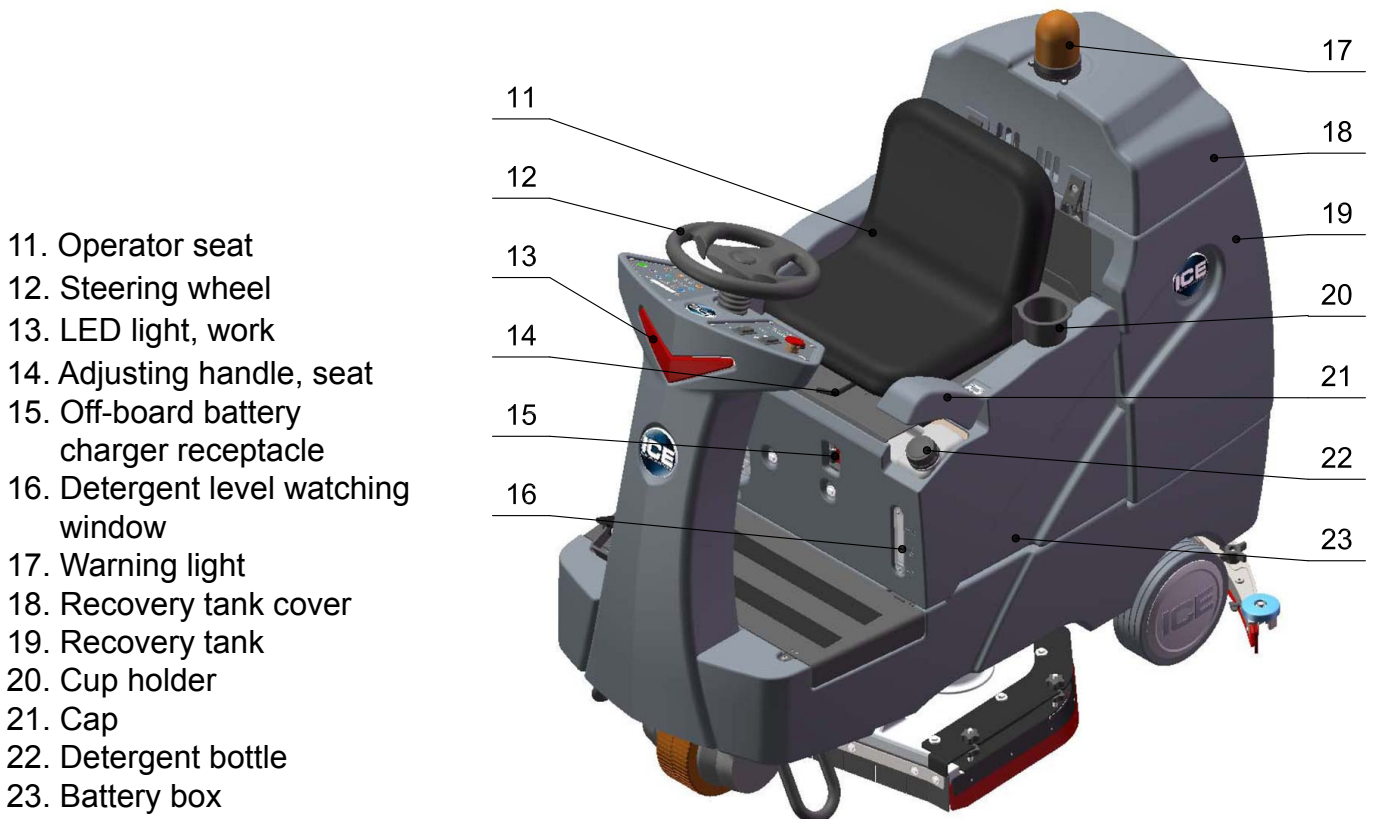

- 11. Operator seat
- 12. Steering wheel
- 13. LED light, work
- 14. Adjusting handle, seat
- 15. Off-board battery charger receptacle
- 16. Detergent level watching window
- 17. Warning light
- 18. Recovery tank cover
- 19. Recovery tank
- 20. Cup holder
- 21. Cap
- 22. Detergent bottle
- 23. Battery box

**MACHINE COMPONENTS**

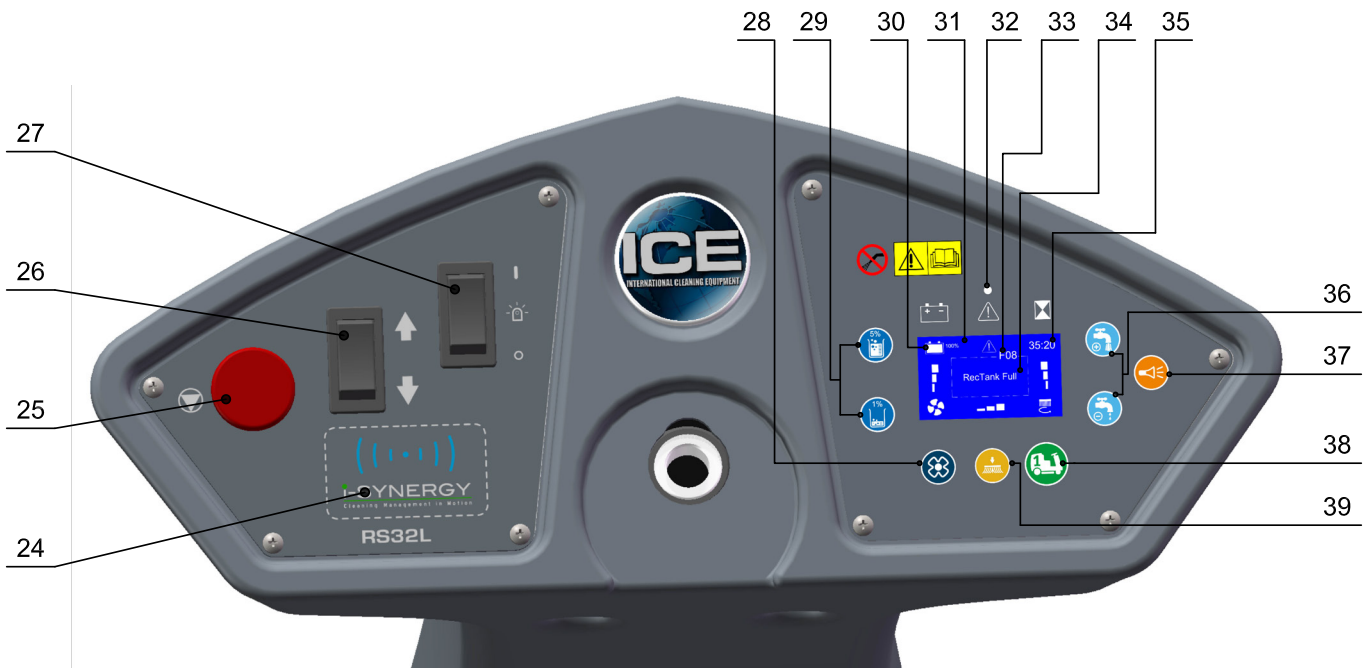

- 24. i-synergy™, ID card scanning area
- 25. Emergency stop switch
- 26. Directional switch
- 27. Warning light switch
- 28. Vacuum motor switch & indicator
- 29. Detergent dosage adjusting buttons & indicator
- 30. Batteries meter
- 31. LED display screen
- 32. Fault indicator
- 33. Fault code
- 34. Fault message
- 35. Hour meter
- 36. Solution flow adjusting buttons & indicator
- 37. Horn button
- 38. 1-Step switch & Indicator
- 39. Brush pressure adjusting button & indicator
- 40. Drain hose, recovery tank
- 41. Drain hose, solution tank
- 42. Vacuum hose

# OPERATOR MANUAL

## i-synergy™ INTRODUCTION

i-synergy™ collects operational data from cleaning machines and transmit the information to ICE's server. The ICE server generates daily reports and send them to designated end users by email. From these reports, end users will have information about machines' usage and even specific timings.

Besides, i-synergy™ also collects data on lithium-ion battery, vacuum motor, brush deck motor, transaxle, and other electrical components at least once every minute when the machine is in use and even during battery charging.

i-synergy™ will send notifications instantly to the ICE server in case of any malfunction. ICE maintenance personnel will receive a SMS within minutes from the ICE server for immediate servicing.

## MACHINE SET UP & INSTALLATION

### UNCRATING MACHINE

Be sure and check packing carton for any damage. Immediately report any damage to carrier. Check the contents of package to ensure that the following items are included:

- Machine
- Lithium-ion Batteries
- Squeegee assembly
- 2-Pad drivers

1. Uncrate the wooden box, place the top board on the edge of pallet, lie in the front of the machine, as below shown.



**! WARNING: Do not operate machine unless you have read & understood this manual.**

2. Install batteries.(see *INSTALLING BATTERIES*)
3. Place the ID card on the scanning area (machine components, #24) to turn on the machine, make sure the Squeegee assembly (machine components, #3) and the Scrub head assembly (machine components, #5) is off the floor.

4. Sit in the Operator seat (machine components, #11), hold the Steering wheel (machine components, #12), press the Propel pedal (machine components, #9) and driving slowly the machine down from the slope.

### INSTALLING BATTERIES

The machine uses the Lithium-ion batteries, the batteries are already in the machine upon delivery; However you will need to connect the Lithium ion batteries to the machine.

**! WARNING: Fire or Explosion Hazard. Keep sparks and open flames away! Keep battery compartment open when charging.**

1. Turn off the machine.
2. Open and prop up the Operator seat, plug the batteries connector to the machine adaptor, connect machine i-synergy™ COM port to the batteries.

### MACHINE SET UP

#### INSTALLING BRUSHES OR PADS

1. Turn off the 1-Step switch (machine components, #38) and raise the Scrub head assembly off the floor, then stop machine on the level surface, ensure the machine is turned off.
2. If using the pad driver, first attach the appropriate pad to the pad driver surface.
3. Align the pad driver or brush under the motor hub and push it upward to engage.



4. To remove the pad driver or brush, raise the scrub head and remove the Side squeegee assembly (machine components, #6), push the edge of brush downward.

## MOUNTING THE SQUEEGEE ASSEMBLY

1. Turn off the 1-Step switch and raise the Squeegee assembly off the floor.
2. Mount the squeegee assembly to the squeegee pivot bracket. make sure the knobs are completely seated into the slots before securing knobs.
3. Connect the Vacuum hose (machine components, #42) to the squeegee assembly. Loop the hose by using the hose clip provided.
4. Check the squeegee blades for proper adjustment.

## FILLING THE SOLUTION TANK

The machine is equipped with a Hose fill-port (machine components, #2) at the side of the machine, and a bucket fill-port located under the recovery tank.

**NOTE: Before accessing the bucket fill-port make sure that the recovery tank is empty. When filling the solution tank with a bucket, make sure that the bucket is clean. Do not use the same bucket for filling and draining the machine.**



**WARNING: Do not put any flammable materials into solution tank. this can cause an explosion or a fire.**

## FILLING THE DETERGENT BOTTLE

The machine is equipped with a 6 liters Detergent bottle (machine components, #22). Open the Cap (machine components, #21) you can fill detergent, and watch the liquid level on the Detergent level watching window (machine components, #16).

The ratio of water and detergent is 0~5%, you can adjust this ratio via pressing the Detergent dosage adjusting buttons (machine components, #29).

**NOTE: Only use recommended cleaning chemicals. Contact your janitorial supply distributor for recommendations on proper chemicals.**

## MACHINE OPERATION



**WARNING: Do not operate machine unless you have read and understand this manual.**

### PRE-OPERATION CHECKS

1. Check the tank cover seals for damage.
2. Drain the recovery tank, check the vacuum fan inlet filter, clean them if necessary.
3. Check the vacuum hose for debris or blockage.
4. Check the squeegees for damage, wear and for deflection adjustment.
5. Check whether Pad/Brush is installed properly .
6. Check the brakes and steering for proper operation.

### OPERATION THE MACHINE

1. Sit in the Operator seat, adjusting the seat to comfortable place by pushing the Seat adjustment handle (machine components, #14).

**NOTE: The machine will not travel unless the operator is sitting in the operator seat.**

2. Turn on the machine.  
Check the LED display screen (machine components, #31) , if there are fault codes (machine components, #33) and the Fault indicator (machine components, #32) is blink, please Do Not operation the machine unless the faults have been eliminated (please see *FAULT CODES AND ELIMINATE* section).
3. Select the preferred settings by pressing the Brush pressure adjusting buttons (machine components, #39) , Solution flow adjusting buttons (machine components, #36) and Detergent dosage adjusting buttons.

**NOTE: Use the minimal pressure and flow as possible.**

4. Turn on the 1-Step switch, the Scrub head assembly and the Squeegee assembly will lower down automatically, all the presetting functions will turn on.
5. The machine can scrub in both forward and backward, place the Directional switch (machine components, #26) in the forward direction is to move forward, backward is to move backward. The horn will sound and the squeegee will raise automatically (the vacuum motor will turn off after a short delay) when drive machine backwards. This is to prevents damaging the squeegee.

**NOTE: Go slow when drive machine backwards.**



# OPERATOR MANUAL

6. Press the Propel pedal, the machine start scrubbing, the speed can be adjusted by controlling the force of foot stepping, light is slow, heavy is fast.

**NOTE: Go slow on inclines and slippery surfaces.**

7. To stop scrubbing, turn off the 1-Step switch, the scrub head will raise automatically, the squeegee will also raise after a short delay (the vacuum indicator flashing), please keep moving until the dirty water is picked up, and then release the propel pedal and stop scrubbing.

8. Turn off the machine.

## **BRAKE DEVICE**

The machine is driven by the Front drive wheel (machine components, #10), that is equipped with a brake device. When you release the Propel pedal, the machine will stop travel, the park brake will engage after a short delay.

The machine is equipped with a Brake pedal (machine components, #8), that can be used to control the machine if quicker stopping is needed or if operating on an incline.

## **EMERGENCY STOP BUTTON**

The machine is equipped with an Emergency stop button (machine components, #25), please push it if an emergency, that will shut off all power of machine and brake immediately.

To restart the machine, please reset the Emergency stop button, and turn off the machine and then restart.

**NOTE: Please hold the steering wheel when emergency stop.**

## **WHILE OPERATING MACHINE**

 **WARNING: Fire Or Explosion Hazard. Do Not Pick Up Flammable Materials Or Reactive Metals.**

1. Go slow on inclines and slippery surfaces, go slow when turn and reverse. Do not operate the machine on inclines that exceed 7% (4°).
2. Drive machine in a straight path as possible, avoid turning the Steering wheel too sharply when machine is in motion. avoid sudden turns except emergencies.
3. Do not keep the machine in the same position with pad / brush spinning, keep the machine moving to prevent damage to floor finish.
4. If the squeegee assembly leaves streaks on the floor, raise the squeegee off the floor and wipe

the blades down with a damp cloth. Pre-sweep the area to prevent leaving streaks on the floor.

5. To obtain the optimum cleaning performance, you can adjust the brush pressure, solution flow and detergent dosage as your required. If poor picking up water performance is observed, please stop scrubbing and check the squeegee blade, adjust or replace if necessary.
6. If the dirty water path exceed the width of squeegee, please adjust the side squeegee assembly.
7. Pour a recommended defoamer into the recovery tank if excessive foam appears.

 **WARNING: The foam do not activate water level switch, excessive foam may result in vacuum motor damage.**

8. Press the Horn button (machine components, #37) to alert if necessary.
9. The machine is equipped with a Warning light (machine components, #17), you can select turn ON or OFF by the Warning light switch (machine components, #27).
10. If there is a fault code F10 (Batt low) on the LED display screen, the machine will stop scrubbing and alarm, please drive the machine to charging.
11. If there is a fault code F08 (Rec Tank Full) on the LED display screen, the vacuum motor will stop working and alarm, please drive the machine to drain water.  
If there is a fault code F09 (Soln Tank Empty) on the LED display screen, the Detergent system will stop working and alarm, please fill the solution tank.
12. If there are other fault codes on the LED display screen, please turn off the machine, eliminate the fault (please see FAULT CODES AND ELIMINATE section), then restart machine.
13. For heavily soiled areas, please use DOUBLE SCRUBBING mode.  
The first time: Turn on the 1-Step switch, then press the Vacuum motor switch (machine components, #28), its indicator will turn off and the squeegee will raise automatically, then start to scrubbing this areas without picking up water.  
The second time: turn on the Vacuum motor switch, the squeegee will lower down automatically, and then start to scrubbing and picking up water.
14. If you only want to pick up water needn't scrubbing, Turn on the Vacuum motor switch (squeegee will lower down) and turn off the 1-Step switch (if it is ON), the scrub head will raise and then start to working.

## TANK DRAINING

### DRAINING THE RECOVERY TANK

Any time scrubbing is completed, or when refilling solution tank, the recovery tank should be drained and cleaned.

 **WARNING:** If the recovery tank is not drained when the solution tank has been refilled, foam or water may enter the float shut-off screen and cause damage to the vacuum motor.

1. While holding the Recovery tank drain hose (machine components, #40) upward, remove the cap and lower hose to drain.
2. Open the Recovery tank cover (machine components, #18) and rinse out the tank. Use a rag to remove any excess dirt.
3. Remove and clean the vacuum fan inlet filter located in the recovery tank. Clean the filter with a damp cloth or low pressure water hose if dirty. Allow the vacuum fan filter to dry completely before reinstalling it in the machine.

### DRAINING THE SOLUTION TANK

Any time scrubbing operation is completed, the solution tank should be drained and cleaned.

1. While holding the Solution tank drain hose (machine components, #41) upward, remove the cap and lower hose to drain.
2. Rinse the solution tank with clean water after every use. This will help prevent chemical buildup and clogging of the solution lines.

## BATTERY CHARGING

 **WARNING:** Fire Or Explosion Hazard. Keep Sparks and Open Flame Away. Keep Battery Compartment Propped Open When Charging.

Use only ICE supplied or approved batteries charger, use unapproved charger may cause damage to the batteries and machine.

*Batteries charger specifications:*

- Applicable to charging Lithium-ion batteries
- Automatic shut off circuit
- Output current of 30 Amps
- Output voltage of 24 volts

1. Transport the machine to a well ventilated area.
2. Turn the machine off.
3. Prop up the Operator seat by the support stand for ventilation.
4. Connect the charger's AC power supply cord to a properly grounded receptacle.
5. The charger will automatically begin to charge, you can watching the charging status on the window (machine components, #7), once the charging cycle begins, the indicator lights will progress from red, yellow to green. when the green indicator light comes on, the charging cycle is done. Unplug the charger cord.

**NOTE:** *The machine will can not operate when charging.*

## PREVENTATIVE MAINTENANCE



**WARNING:** Before performing any maintenance on the machine, be sure that the power is turned off, or the batteries are disconnected!



**WARNING:** Repairs are to be completed by Authorized service centers only. Any repairs completed by unauthorized persons will void the warranty.

### DAILY MAINTENANCE

1. Remove pad driver/ brush and clean with approved cleaner.
2. Drain recovery and solution tanks completely and rinse out with clean water. Visually check the recovery tank for debris and clean out as necessary.
3. Raise the squeegee assembly off floor and wipe it down with a damp towel. Be sure to store the squeegee in the up position.
4. Remove the vacuum fan inlet filter and rinse it out with clean water.
5. Clean machine with an approved cleaner and a damp towel.
6. Recharge the batteries.
7. Check the condition of the squeegee blade wiping edge, rotate blade if worn.

### MONTHLY MAINTENANCE

1. Clean the battery tops to prevent corrosion.
2. Check for loose battery cable connections.
3. Inspect and clean the recovery tank cover seal. Replace it if damaged.
4. Lubricate all grease points and pivot points with silicon spray and approved grease.
5. Check the machine for loose nuts and bolts.
6. Check the machine for leaks.

### MACHINE STORAGE

1. Always store the machine indoors.
2. Always store the machine in a dry area.
3. Always store the machine in its upright position.
4. Always store the machine with the pad driver/ brush raised off the floor.
5. Always store the machine with the squeegee assembly raised off the floor.
6. If storing in an area which may reach freezing temperatures, be sure to drain all fluids from the machine prior to storage. Any damage caused by freezing temperatures will not be covered by the warranty.
7. Drain the recovery tank.
8. Drain the solution tank of all fluid.

## FAULT CODE & SOLUTION

The machine is equipped with a LED display screen (see Machine components, item # 31), the LED screen will display the operating hours (see Machine components, item # 35) and the battery level status (see Machine components, item # 30).

When the machine detects a fault, there will be a Fault code (see Machine components, item #33) & Fault message (see Machine components, item #34) display on the LED screen, and the Fault indicator (see Machine components, item #32) will flash continuously, accompany an audible alarm Occasionally.

Once fault occurring, please DO NOT continue operate the machine unless the fault are eliminated. Turn off the machine, then to solve the fault, the fault code & message will be eliminated when machine restart.

If the fault is occurred frequently, or the fault can't be eliminated, please contact ICE service center.

Please refer to the below table to determine the fault cause and the solution.

## FAULT CODE & SOLUTION

FAULT CODE	FAULT MESSAGE	FAULT CAUSE	SOLUTION
F01	Seat Empty	Not sit in the seat	Sit in the operator seat
F02	Squeegee Actt O.L. RE-START!	Squeegee lifting actuator is overload	Turn off the machine,after a moment, RE-START machine.
F03	Bru Actt O.L. RESTART!	Scrub head lifting actuator is overload	
F04	Vac Mtr O.L. RE-START!	Vacuum motor overload	
F05	Left Bru Mtr O.L. RE-START!	Left brush motor is overload	
F06	Right Bru Mtr O.L. RE-START!	Right brush motor is overload	
F07	Propel Mtr O.L. RE-START!	Propel motor overload	
F08	RecTank Full	Recovery tank is full	Drain the Recovery tank
F09	Soln Tank empty	Solution tank is empty	Fill the solution tank
F10	Batt Low Charge Batt	Battery is low	Charge the battery
F11	Batt Empty Charge Batt NOW	Battery is empty	Charge the battery NOW
F12	Brake Wiring Error	Bad Brake wiring	Check the brake wiring
F13	Release Foot pedal	Stepping the propel pedal when starting machine	Release the propel pedal
F14	Replace Brake Assy	Bad Brake assembly	Replace the brake assembly
F16	Control Unit Overheat! Wait	Control Unit Overheat	Turn off the machine,after a moment, RE-START machine
F17	Replace Control Unit	Control Unit Fault	Replace the control unit
F18	Replace Accel Pedal Sensor	Bad Accelerator pedal sensor	Replace accelerator pedal sensor
F19	Replace Brake pedal sensor	Bad Accelerator pedal sensor	Replace accelerator pedal sensor
F20	Check Left Brush motor	Bad left brush motor	Check left brush motor/ wiring
F21	Check Vac Mtr	Bad Vacuum motor or wiring	Check the vacuum motor / Wiring
F22	Check Soln Solenoid	Solution solenoid wiring fault	Check the wiring & Contactors
F23	Replace Soln solenoid	Bad Solution solenoid	Replace the solution solenoid
F24	Check Propel Motor	Bad propel motor	Check the propel motor / Wiring
F25	Check Right Brush motor	Bad right brush motor	Check right brush motor/ wiring
F40	Check Proximity Sw	Proximity switch fault	Check the Proximity switch
F42	Replace Control Unit	Bad Control Unit	Replace the control unit
F43	Turn Dead Sw Off RE-START!	Emergency stop button activated	Release emergency stop button and restart machine
F44	Replace Control Unit	Bad Control Unit	Contact service center, Replace the Control Unit
F45	Return Control Unit		
F46	Return Control Unit		
F47	Return Control Unit		
F48	Return Control Unit		

**TECHNICAL SPECIFICATIONS**

MODEL	RS26L	RS28L	RS32L
LENGTH	61.6 in / 1,565 mm		
WIDTH (MACHINE WITH SCRUB HEAD)	32 in / 815 mm	33.7 in / 855 mm	37.4 in / 950 mm
HEIGHT	56.7 in / 1,440 mm		
WEIGHT	618 lbs / 280 Kg		640 lbs / 290 Kg
WEIGHT WITH BATTERIES	880 lbs / 400 Kg		900 lbs / 410 Kg
RECOVERY TANK CAPACITY	29 Gal / 110 L		
SOLUTION TANK CAPACITY	29 Gal / 110 L		
SQUEEGEE WIDTH	33.8 in / 860 mm	40 in / 1,030 mm	
CLEANING PATH WIDTH	26 in / 650 mm	28 in / 710 mm	32 in / 810 mm
PRODUCTIVITY RATE PER HOUR (IN THEORY)	46,300 ft <sup>2</sup> 4,300 m <sup>2</sup>	49,500 ft <sup>2</sup> 4,600 m <sup>2</sup>	55,600 ft <sup>2</sup> 5,200 m <sup>2</sup>
TRAVEL SPEED (TRANSPORT)	4 Mile / h 6.5 Km / h		
MINIMUM AISLE TURN	71 in / 1,800 mm	75 in / 1,900 mm	
PAD/BRUSH PRESSURE	80 lbs / 35 Kg 120 lbs / 55 Kg 160 lbs / 75 Kg		
SOLUTION FLOW	0 ~ 0.7 Gal / Min 0 ~ 2.7 L / Min		
BATTERIES	Lithium-ion batteries, 240AH		
VOLTAGE	24V DC		
DRIVE WHEEL	1.1 hp / 0.8 KW		
BRUSH MOTOR	(2) 0.6 hp / 0.45 KW, 210 RPM		
VACUUM MOTOR	0.6 hp / 0.45KW		
VACUUM WATER LIFT (MAX)	70 in. H <sub>2</sub> O / 1780 mm. H <sub>2</sub> O		
RUN TIME PER CHARGE	3~3.5 Hours		
DECIBEL RATING AT OPERATOR'S EAR, INDOORS	68 dB(A)		
GRADE LEVEL, MAX	Scrubbing: 4°/7%	Transporting (empty):10°/17.5%	

**MAIN FRAME GROUP**

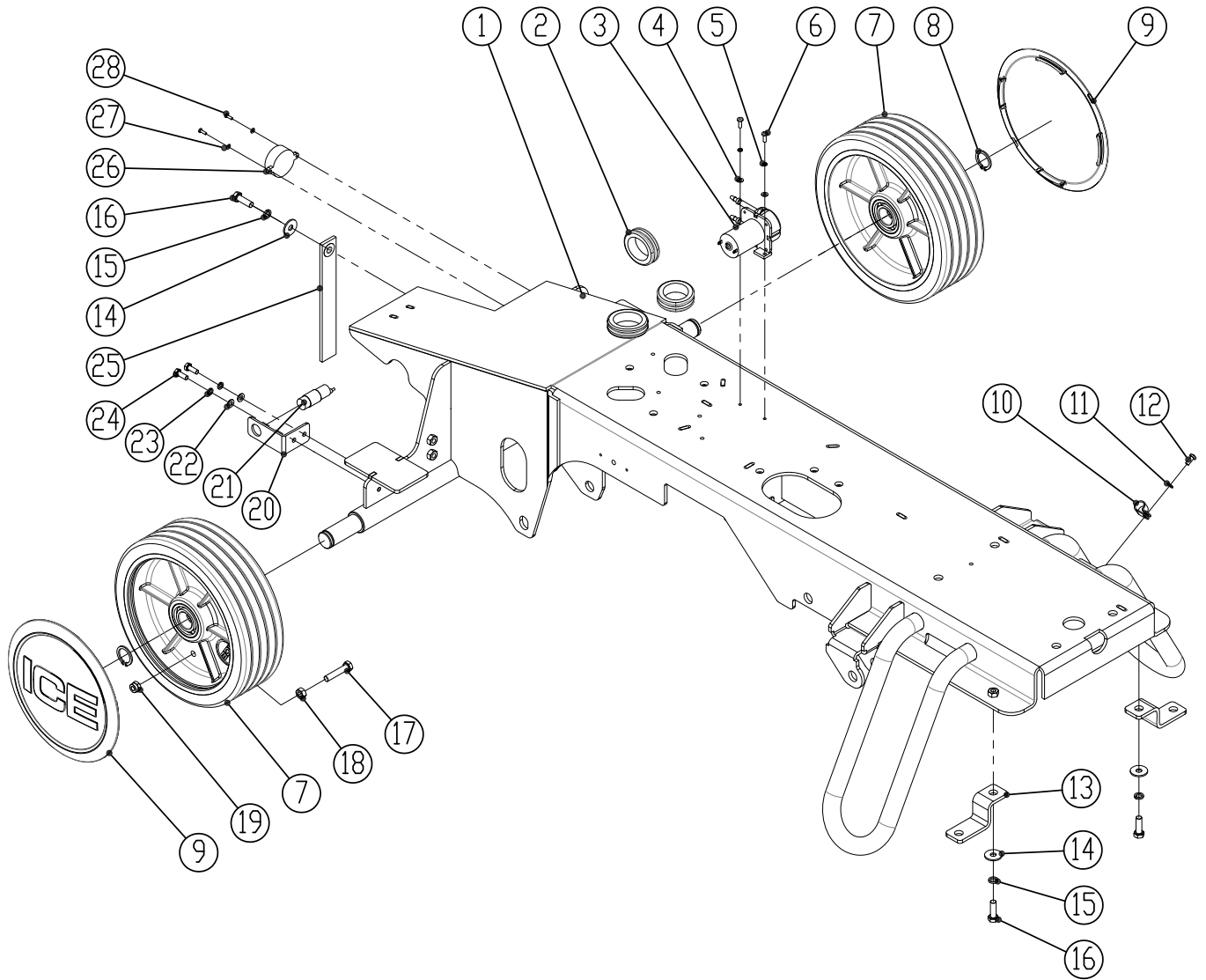

## PARTS LIST

### MAIN FRAME GROUP

DIA NO.	PART NUMBER	DESCRIPTION	NO REQ'D
1	8310102	MAIN FRAME, WELDED	1
2	8310133	RUBBER GROMMET	5
3	8310930A	PERISTALTIC PUMP, KIT	1
	8310931	TUBING, PUMP	1
4	1421409	FLAT WASHER, M4× $\phi$ 9×0.8	2
5	1422411	LOCK WASHER M4	2
6	1221412	SCREW, PAN HEAD, M4×12	2
7	8310119	10" WHEEL, PU TIRE	2
	1612605	BALL BEARING,6205-2RS	4
8	1436025	RETAINING RING, 25MM	2
9	8310150	WHEEL CAP	2
10	6210131	NYLON, CLAMP	5
11	1421510	FLAT WASHER, M5× $\phi$ 10×1.0	5
12	1221512	SCREW, PAN HEAD, M5×12	5
13	8310120	BRACKET, STAND	2
14	1421824	FLAT WASHER, M8× $\phi$ 24×2.0	3
15	1422821	LOCK WASHER M8	3
16	1021825	BOLT, HEX, M8×25	3
17	1021840	BOLT, HEX, M8×40	1
18	1121807	HEX NUT, M8	1
19	1123810	LOCK NUT M8	1
20	8310158	BRACKET,PROXIMITY SENSOR	1
21	8134709A	PROXIMITY SENSOR, KIT	1
22	1421612	FLAT WASHER, M6× $\phi$ 12×1.6	2
23	1422616	LOCK WASHER M6	2
24	1021616	BOLT, HEX, M6×16	2
25	8210118	STATIC STRAP	1
26	8310708A	HORN, 24VDC, KIT	1
27	1421307	PLAT WASHER, M3× $\phi$ 7×0.5	4
28	1211316	SCREW, PAN HEAD, M3×16	2

**STEERING & DRIVE WHEEL GROUP**

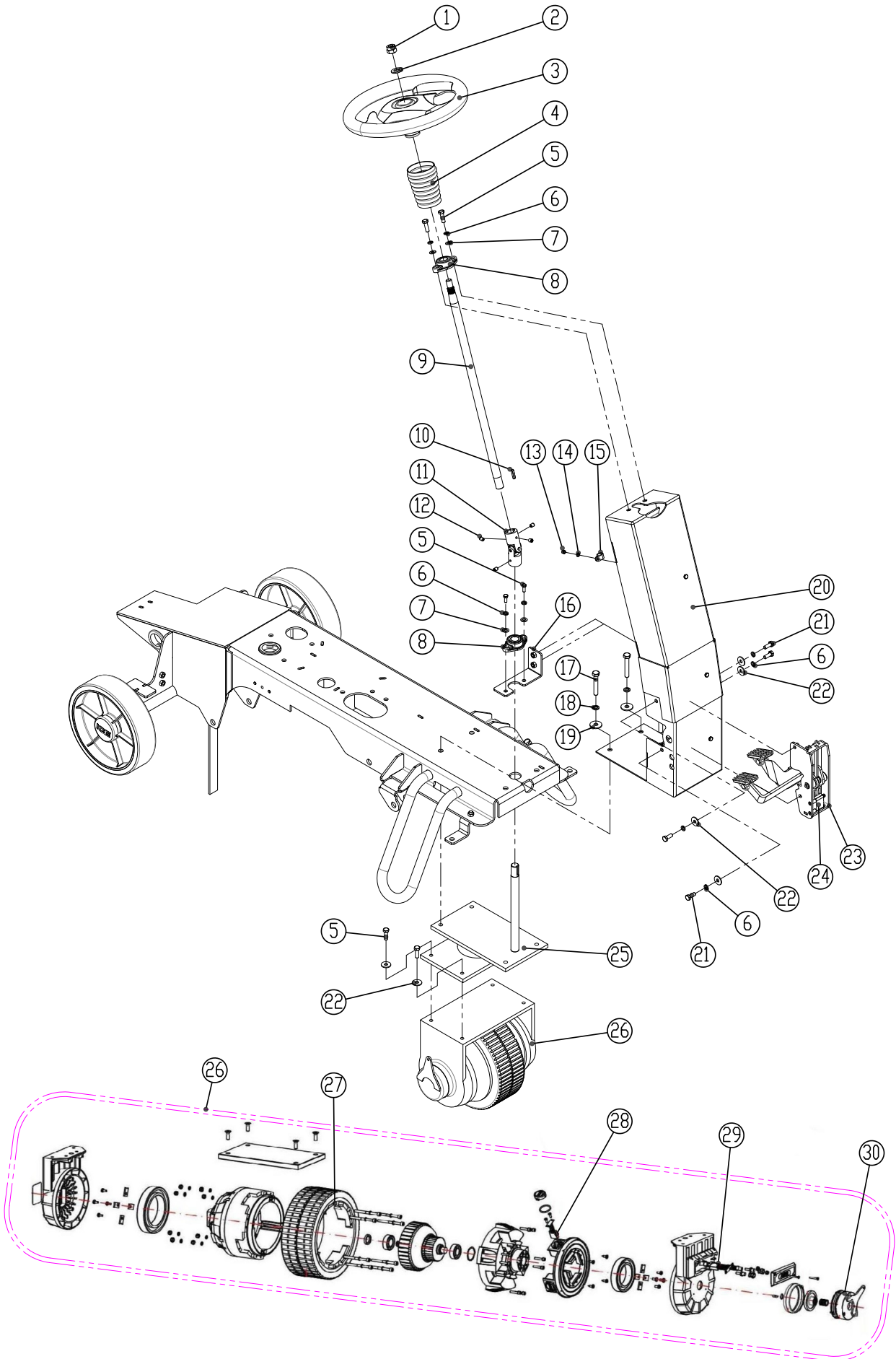



## PARTS LIST

### STEERING & DRIVE WHEEL GROUP

DIA NO.	PART NUMBER	DESCRIPTION	NO REQ'D
1	1113014	LOCK NUT, M14	1
2	1421428	FLAT WASHER, M14× $\phi$ 28×2.0	1
3	8310602	STEERING WHEEL	1
	8310699A	CUSHION WITH ICE LOGO	1
4	8310608	BELLOWS, SHAFT, STEERING	1
5	1021825	BOLT, HEX HEAD, M8×25	8
6	1422821	LOCK WASHER, M8	6
7	1421816	FLAT WASHER, M18× $\phi$ 16×1.6	4
8	8310609	BEARING, FLANGE	2
9	8310605	SHAFT, STEERING WHEEL	1
10	1654025	KEY, 4.75×4.75×25.4	2
11	8310604	U-JOINT	1
12	1534508	SET SCREW, M5 ×8	4
13	1123507	LOCK NUT, M5	3
14	1421510	FLAT WASHER, M5× $\phi$ 10×1.0	3
15	6210131	CLAMP, NYLON	3
16	8310645	BRACKET, FLANGE BEARING	1
17	1021060	BOLT, HEX HEAD, M10×60	4
18	1422026	LOCK WASHER, M10	4
19	1421030	FLAT WASHER, M10× $\phi$ 30×2.5	4
20	8310601	SUPPORT BRACKET, STEERING	1
21	1021820	BOLT, HEX HEAD, M8×20	4
22	1421824	FLAT WASHER, M14× $\phi$ 24×2.0	8
23	8310640	ACCELERATOR/ BRAKE PEDAL	1
24	8310431	HALL SENSOR WITH CABLE	1
25	8310603	STEER-CONTROL ASSY.	1
26	8310650	DRIVE WHEEL, 24VDC 800W	1
27	8310611	PU TIRE, DRIVER WHEEL	1
28	8310612	ARMATURE BRUSH	4
29	8310613	BRUSHES CONNECTION BOX	2
30	8310618A	ELECTRICALLY RELEASED BRAKE	1

**SOLUTION TANK GROUP**

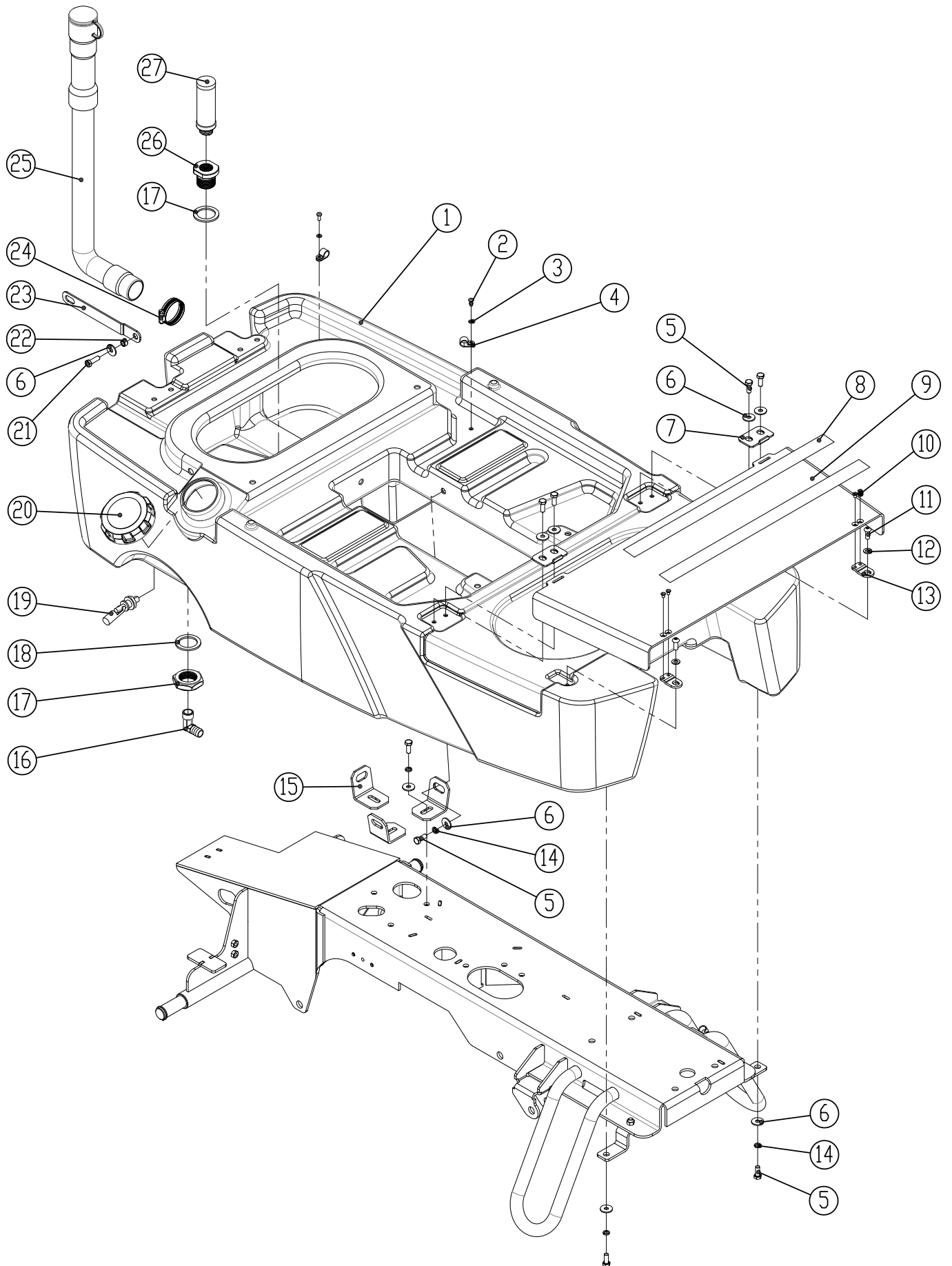

## **PARTS LIST**

### **SOLUTION TANK GROUP**

<b>DIA NO.</b>	<b>PART NUMBER</b>	<b>DESCRIPTION</b>	<b>NO REQ'D</b>
1	8310101	SOLUTION TANK	1
2	1221512	SCREW, PAN HEAD, M5×12	2
3	1421510	FLAT WASHER, M5× $\phi$ 10×1.0	2
4	8113009	CLAMP, NYLON	2
5	1021820	BOLT, HEX HEAD, M8×20	12
6	1421824	FLAT WASHER, M8× $\phi$ 24×2.0	13
7	8310139	PLATE	2
8	8310151A	NON-SLIP MAT	2
9	8310132	FOOTREST PLATE	1
10	1222508	SCREW, M5×8	4
11	1512820	SCREW, HEX SOCKET, M8×20	2
12	1421816	FLAT WASHER, M8× $\phi$ 16×1.6	2
13	8310140	JUNCTION PLATE	2
14	1422821	LOCK WASHER, M8	8
15	8310130	BRACKET, SOLUTION TANK MNTG	3
16	8310124	ELBOW, G1/2	1
17	8310142	NUT, M36	1
18	8310141	SEALING	2
19	8310238A	SENSOR, SOLUTION LEVEL, KIT	1
20	8310125	CAP, SOLUTION TANK	1
21	1021825	BOLT, HEX HEAD, M8×25	1
22	8310225	SLEEVE, $\phi$ 8.1× $\phi$ 12.7×7.8	1
23	8310224	ARM, RECOVERY TANK SUPPORT	1
24	1962050	CLAMP, 2 INCH	1
25	8011030	HOSE ASSEMBLY	1
26	8310123	ADAPTER, STRAINER ASSY	1
27	8310122	STRAINER ASSY	1

**RECOVERY TANK GROUP**

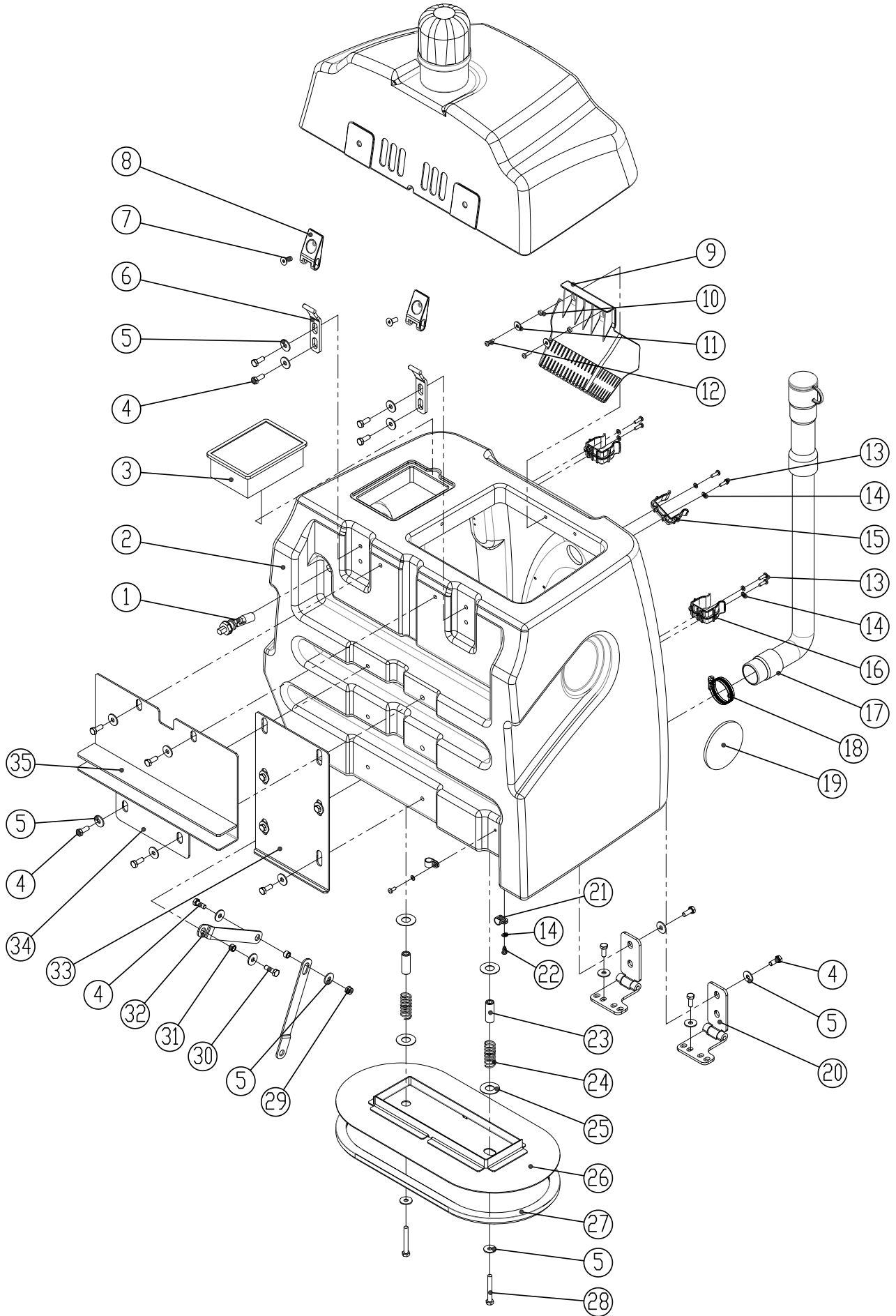

## PARTS LIST

### RECOVERY TANK GROUP

DIA NO.	PART NUMBER	DESCRIPTION	NO REQ'D
1	8310238A	SENSOR, SOLUTION LEVEL, KIT	1
2	8310201	RECOVERY TANK	1
3	8310237	FILTER, DUST	1
4	1021820	BOLT, HEX HEAD, M8×20	21
5	1421824	FLAT WASHER, M8× $\phi$ 24×2.0	25
6	8310227	HINGE, WELDED	2
7	1513820	SCREW, HEX SOCKET, M8×20	2
8	8310226	HINGE, LEAF	2
9	8310250	DEBRIS COLLECTOR	1
10	8012008	BUSHING	2
11	1421618	FLAT WASHER, M6× $\phi$ 18×1.6	2
12	1321413	SELF-TAPPING, ST4.8 x 13	2
13	1221516	SCREW, PAN HEAD, M5×16	8
14	1421510	FLAT WASHER, M5× $\phi$ 10×1.0	12
15	2310129	CLAMP, HOSE	2
16	6210111	CLAMP, HOSE	2
17	8011030	DRAIN HOSE	1
18	1962050	CLAMP, 2 INCH	1
19	4010316	ICE LOGO	2
20	8310126	HINGE ASSY.	2
21	8113009	CLAMP, NYLON	4
22	1221512	SCREW, PAN HEAD, M5×12	4
23	8310221	SPACER	2
24	8310220	COMPRESSION SPRING	2
25	8310222	FLAT WASHER, LARGE	4
26	8310216	COVER, SOLUTION TANK	1
27	8310219	SEALING STRIP	1
28	1022860	BOLT, HEX HEAD, M8×60	2
29	1123810	LOCK NUT, M8	1
30	1021825	BOLT, HEX HEAD, M8×25	1
31	8310225	SLEEVE, $\phi$ 8.1× $\phi$ 12.7×7.8	2
32	8310223	ARM, RECOVERY TANK SUPPORT	1
33	8310215	BRACKET, RECOVERY TANK SUPPORT	1
34	8310211	BRACKET, SUPPORT	1
35	8310214	SPACER, RUBBER	1

**RECOVERY TANK COVER GROUP**

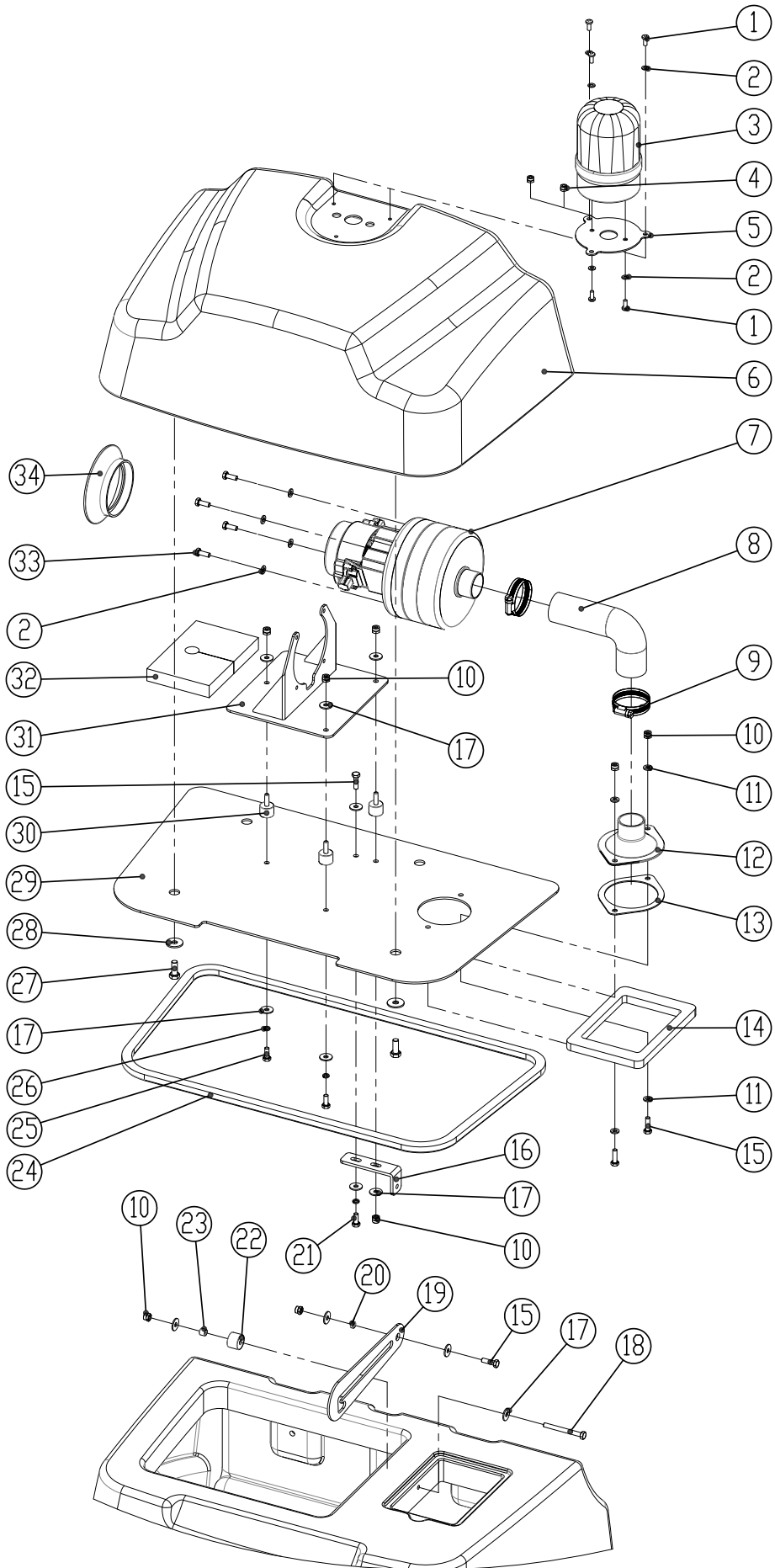

## PARTS LIST

### RECOVERY TANK COVER GROUP

DIA NO.	PART NUMBER	DESCRIPTION	NO REQ'D
1	1221512	SCREW, PAN HEAD, M5×12	5
2	1421510	FLAT WASHER, M5×φ10×1.0	9
3	8310138A	CAUTION LIGHT, KIT	1
4	1123507	LOCK NUT, M5	2
5	8310241	PLATE, CATUION LIGHT	1
6	8310202	RECOVERY TANK COVER	1
7	8310260	AMETEK VACUUM MOTOR, 3 STAGE, KIT	1
	8132006	CARBON BRUSH FOR VACUUM MOTOR	2
8	8310207	VACUUM HOSE	1
9	1962050	CLAMP, 2 INCH	2
10	1123608	LOCK NUT, M6	8
11	1421612	FLAT WASHER, M6×φ12×1.6	4
12	8310204	ADAPTER, VACUUM HOSE	1
13	8310205	GASKET, ADAPTER	1
14	8310230	GASKET, DUST FILTER	1
15	1021620	BOLT, HEX HEAD, M6×20	4
16	8310232	BRACKET	1
17	1421618	FLAT WASHER, M6×φ18×1.6	12
18	1022600	BOLT, HEX HEAD, M6×100	1
19	8310228	SUPPORT, RECOVERY TANK COVER	1
20	8310231	SLEEVE, φ6.4×φ9.5×4	1
21	1021616	BOLT, HEX HEAD, M6×16	1
22	8310236	SPACER, NYLON	1
23	8310235	SLEEVE, φ6.4×φ9.5×8	1
24	8310229	SEALING STRIP	1
25	1021610	BOLT, HEX HEAD, M6×10	2
26	1422616	LOCK WASHER, M6	3
27	1021820	BOLT, HEX HEAD, M8×20	4
28	1421824	FLAT WASHER, M8×φ24×2.0	4
29	8310203	PLATE, VACCUM MOTOR MNTG	1
30	8310208	ISOLATER, M6	3
31	8310209	BRACKET, VACCUM MOTOR	1
32	8310234	INSULATION	1
33	1311316	SCREW, SELF-TAPPING, ST4.8×16	4
34	8310206	SEAL, FAN	1

**CONTROL PANEL GROUP**

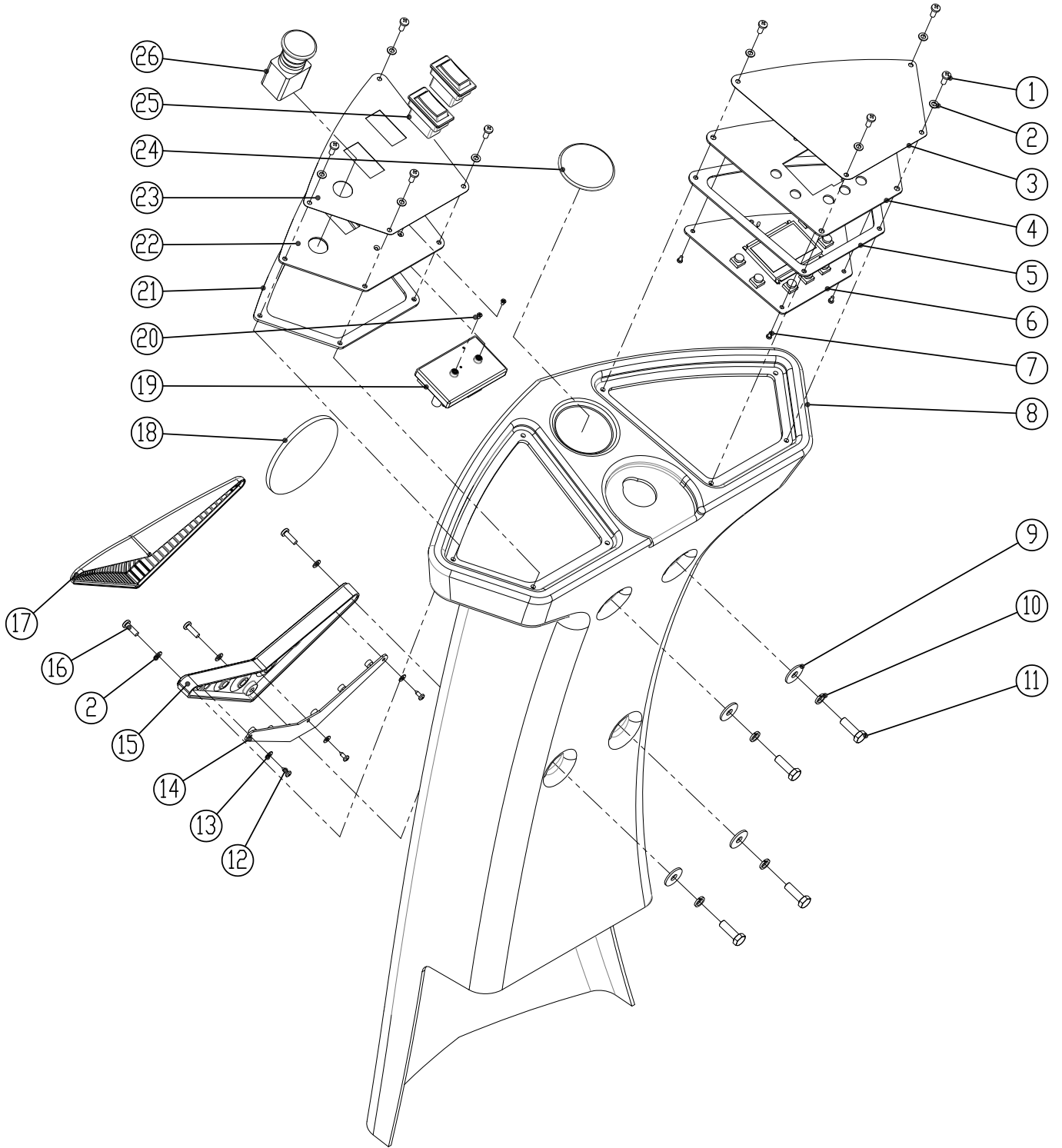



## PARTS LIST

### CONTROL PANEL GROUP

DIA NO.	PART NUMBER	DESCRIPTION	NO REQ'D
1	1221512	SCREW, PAN HEAD, M5×12	8
2	1421510	FLAT WASHER, M5× $\phi$ 10×1.0	11
3	8311703	DECAL, CONTROL PANEL	1
4	8311702	PLATE, CONTROL PANEL	1
5	8310712	GASKET, CONTROL PANEL	1
6	8310776	PCB, CONTROL PANEL (LI / EN)	1
7	1221306	SCREW, PAN HEAD, M3×6	5
8	8310701	CONROL HOUSING	1
9	1421824	FLAT WASHER, M8× $\phi$ 24×2.0	4
10	1422821	LOCK WASHER, M8	4
11	1021825	BOLT, HEX HEAD, M8×25	4
12	1321110	SCREW, SELF-TAPPING, ST3.5×10	3
13	1421409	FLAT WASHER, M4× $\phi$ 9×0.8	3
14	8133610	LED LIGHT, KIT	1
15	8133601	BASE, LED LIGHT	1
16	1221520	SCREW, PAN HEAD, M5×20	3
17	8133602	COVER, LED LIGHT	1
18	4010316	ICE LOGO	1
19	8134768	RFID BOARD	1
20	1222305	SUNK SCREW, M3×5	2
21	8310755	GASKET, SWITCH PANEL	1
22	8311751	PLATE, SWITCH PANEL	1
23	8311752	DECAL, SWITCH PANEL, RS32L	1
	8311753	DECAL, SWITCH PANEL, RS28L	1
	8311754	DECAL, SWITCH PANEL, RS26L	1
24	2010121	ICE LOGO, SMALL	1
25	8310709	ROCKER SWITCH	2
26	8310707	EMERGENCY STOP SWITCH	1

**MAIN CONTROLLER GROUP**

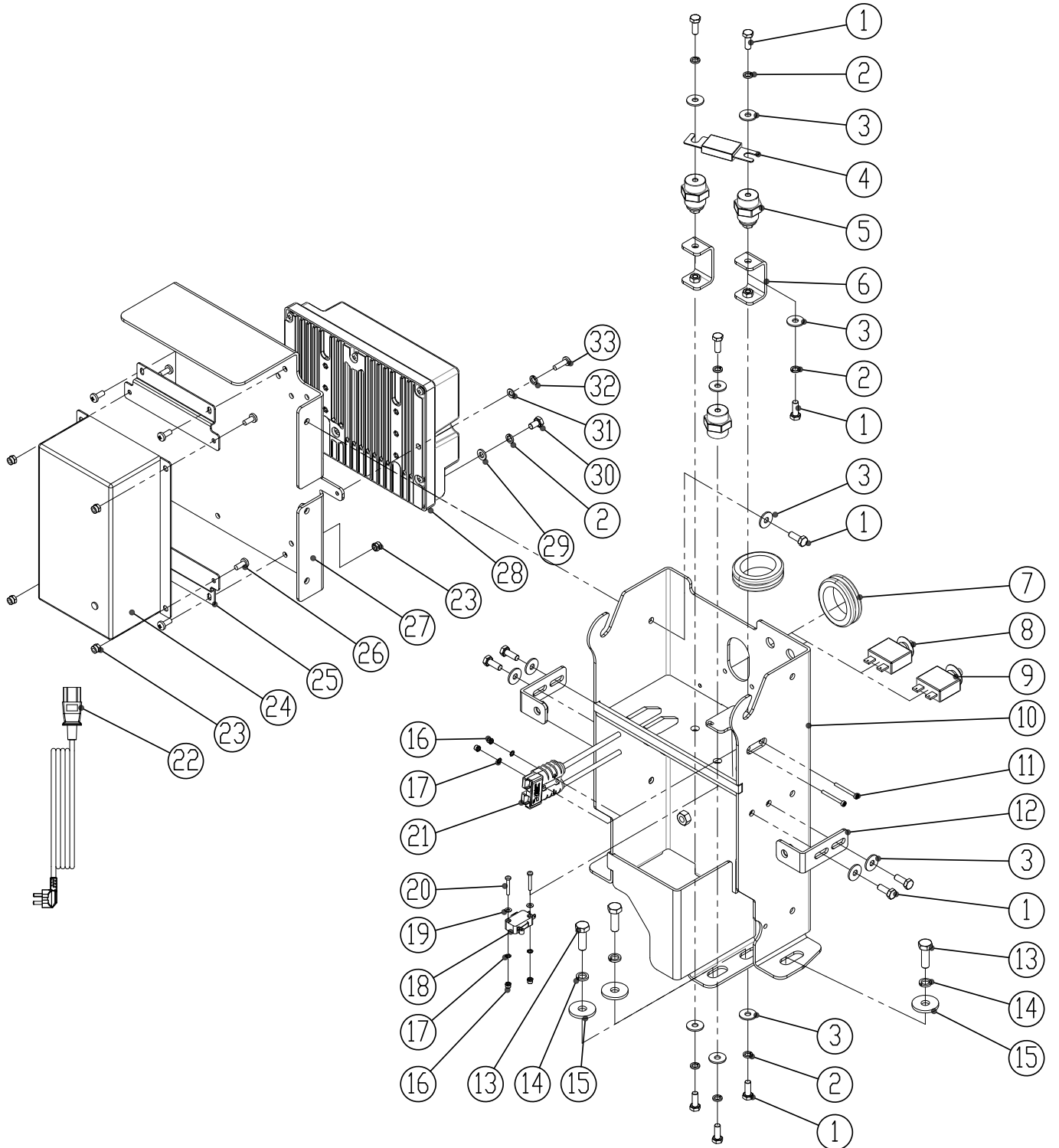

## PARTS LIST

### CONTROLLER GROUP

DIA NO.	PART NUMBER	DESCRIPTION	NO REQ'D
1	1021616	SCREW, HEX HEAD, M6×16	12
2	1422616	LOCK WASHER, M6	18
3	1421618	FLAT WASHER, M6× $\phi$ 18×1.6	15
4	8310480	FUSE, 150A	1
5	8114705	INSULATOR	3
6	8310422	BRACKET, INSULATOR	2
7	8310133	RUBBER GROMMET	2
8	8310740	CIRCUIT BREAKER, 5A	1
9	8014068	CIRCUIT BREAKER, 10A	1
10	8310450	BRACKET, SCRUB HEAD LIFTING	1
11	1211330	SCREW, PAN HEAD, M3×30	2
12	8310425	BRACKET	2
13	1021825	BOLT, HEX HEAD, M8×25	5
14	1422821	LOCK WASHER, M8	5
15	1421828	FLAT WASHER, M8× $\phi$ 28×2.5	5
16	1123305	LOCK NUT, M3	4
17	1434300	WASHER, TOOTH, M3	4
18	8310423	MICRO SWITCH	1
19	1421307	FLAT WASHER, M3× $\phi$ 7×0.5	2
20	1211320	SCREW, PAN HEAD, M3×20	2
21	8311743	OFF BOARD CHARGER SOCKET	1
22	8112030	POWER CORD, BATTERY CHARGER, US	1
23	1123507	LOCK NUT, M5	8
24	8311720	ON BOARD BATTERY CHARGER, 30A	1
25	8311721	BRACKET, BATTERY CHARGER	2
26	1221512	SCREW, HEX HEAD, M5×12	8
27	8310452	BRACKET, BATTERY CHARGER	1
28	8310790	MAIN CONTROLLER	1
29	1423612	FLAT WASHER M6× $\phi$ 12×1, COPPER	10
30	1023612	HEX BOLT M6 X 12, COPPER	10
31	1421510	FLAT WASHER, M5× $\phi$ 10×1.0	2
32	1422513	LOCK WASHER, M5	2
33	1221525	SCREW, HEX HEAD, M5×25	2

**SEAT & DETERGENT SYSTEM GROUP**

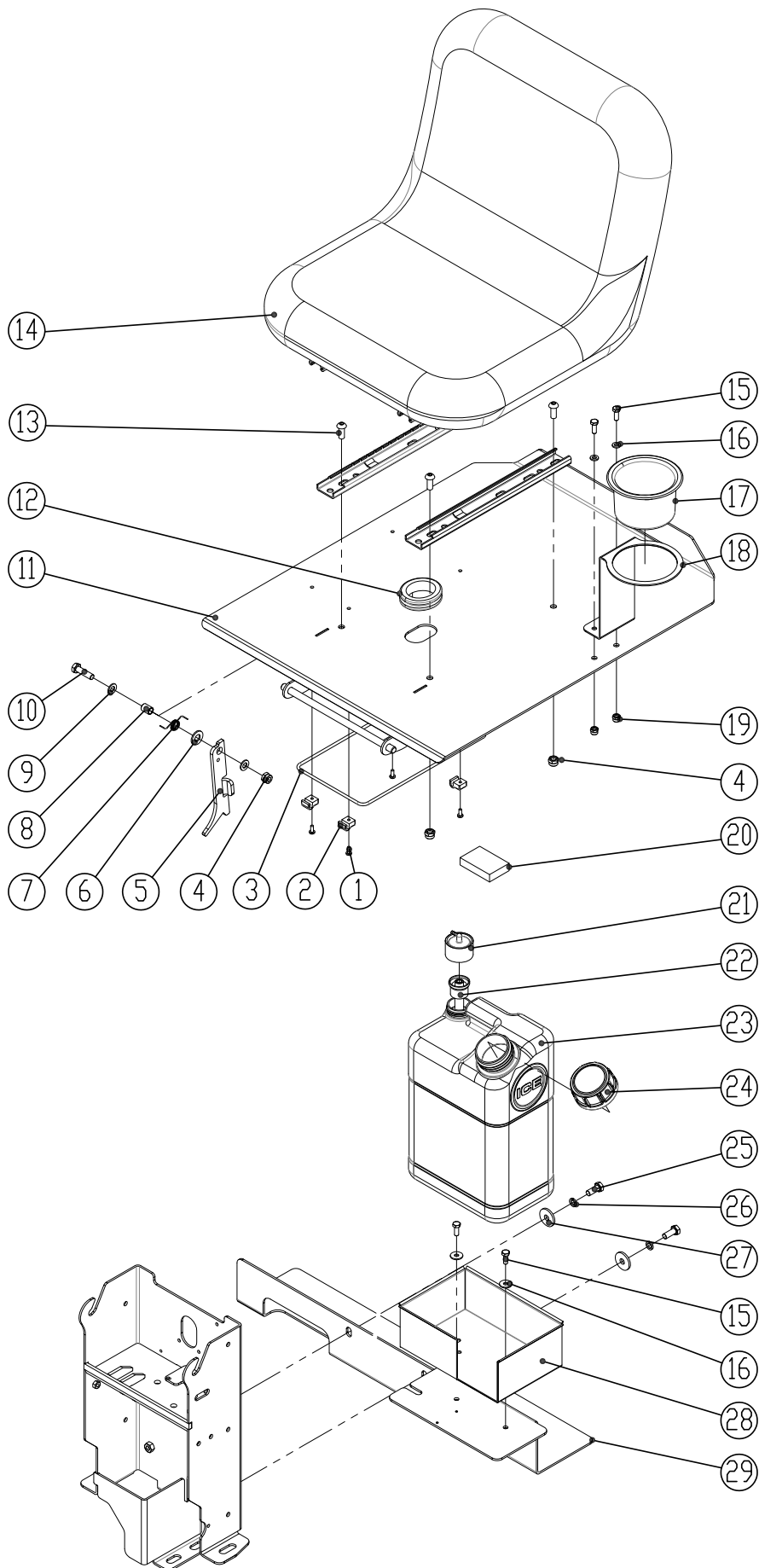

## PARTS LIST

### SEAT & DETERGENT SYSTEM GROUP

DIA NO.	PART NUMBER	DESCRIPTION	NO REQ'D
1	1221412	SCREW, HEX HEAD, M4×12	4
2	8133502	CLAMP	4
3	8133501	CARGO NET	1
4	1123810	LOCK NUT, M8	5
5	8310413	SUPPORT, SEAT	1
6	8117007	NYLON SPACER	1
7	8310415	TORSION SPRING	1
8	8310414	SLEEVE, $\phi 8.2 \times \phi 11 \times 15$	1
9	1421816	FLAT WASHER, M8× $\phi 16 \times 1.6$	2
10	1021830	BOLT, HEX HEAD, M8×30	1
11	8310411	PLATE, SEAT MNTG	1
12	8310133	RUBBER GROMMET	1
13	1512820	SCREW, HEX SOCKET, M8×20	4
14	8310402K	SEAT, KIT	1
15	1021616	SCREW, HEX HEAD, M6×16	4
16	1421618	FLAT WASHER, M6× $\phi 18 \times 1.6$	4
17	8310418	CUP HOLDER	1
18	8310419	BRACKET, CUP HOLDER	1
19	1123608	LOCK NUT, M6	2
20	8310460	SPACER	1
21	8310463	ADAPTOR, KEY	1
22	8310464	INSERT, LOCK	1
23	8310461	BOTTLE, DETERGENT	1
24	8310462	CAP, BOTTLE	1
25	1021820	BOLT, HEX HEAD, M8×20	2
26	1422821	LOCK WASHER, M8	2
27	1421828	FLAT WASHER, M8× $\phi 28 \times 2.5$	5
28	8310465	BOX, DETERGENT BOTTLE	1
29	8310421	BRACKET	1

**BATTERY GROUP**

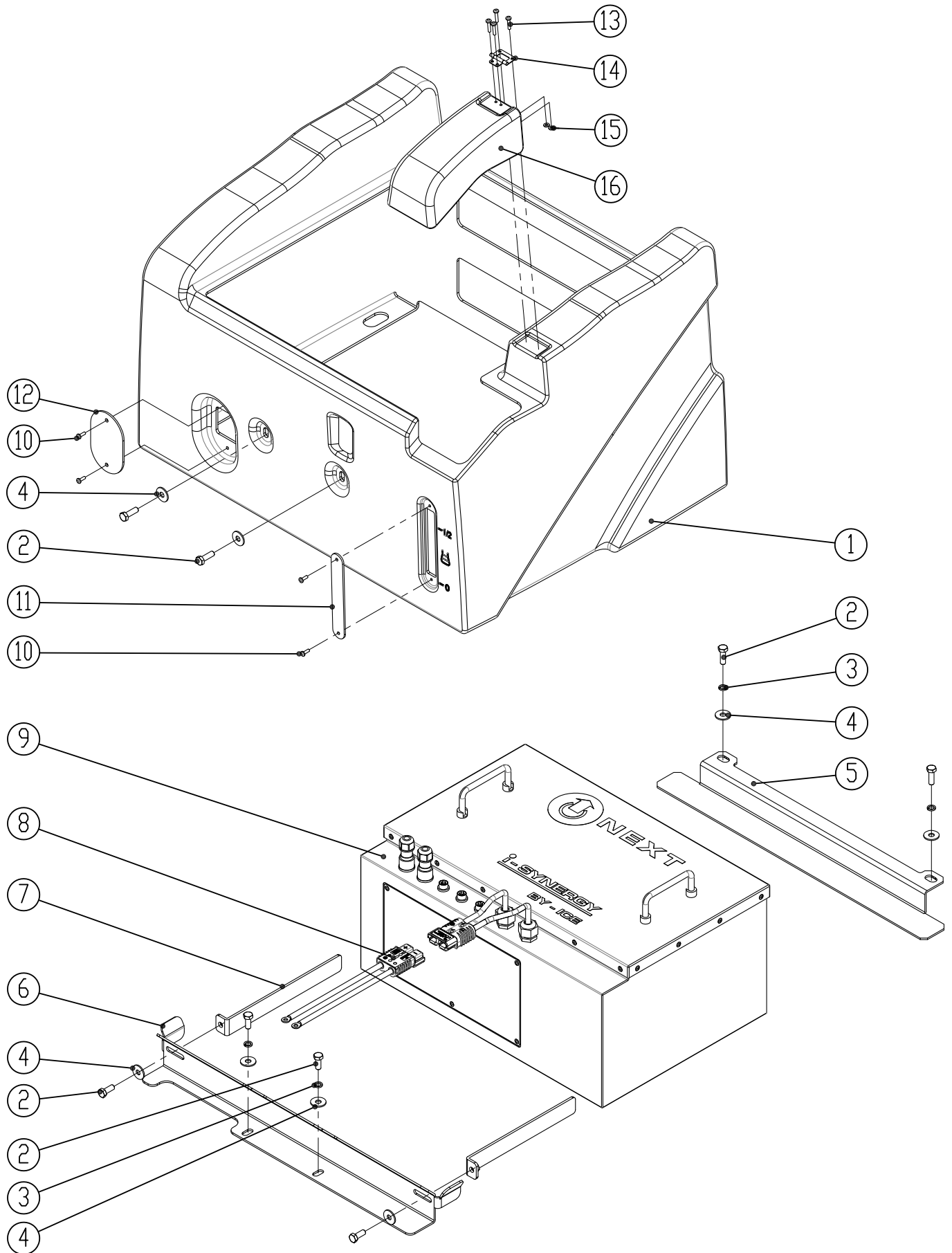

## **PARTS LIST**

---

### **BATTERY GROUP**

<b>DIA NO.</b>	<b>PART NUMBER</b>	<b>DESCRIPTION</b>	<b>NO REQ'D</b>
1	8310401	BOX, BATTERY	1
2	1021820	BOLT, HEX HEAD, M8×20	8
3	1422821	LOCK WASHER, M8	4
4	1421824	FLAT WASHER, M8× $\phi$ 24×2.0	8
5	8310131	SUPPORT, BATTERY, REAR	1
6	8310136	SUPPORT, BATTERY, FRONT	1
7	8310407	PLATE	2
8	8311741	BATTERY CONNECT CABLE	1
9	9324225	LITHIUM-ION BATTERY, 240AH	1
10	1221412	SCREW, PAN HEAD, M4×12	4
11	8310406	COVER	1
12	8210114	COVER	1
13	1662316	RIVET, 3.2×16	4
14	8310404	HINGE ASSEMBLY	1
15	1421409	FLAT WASHER, M4× $\phi$ 9×0.8	4
16	8310403	COVER	1

**SCRUB HEAD LIFTING GROUP**

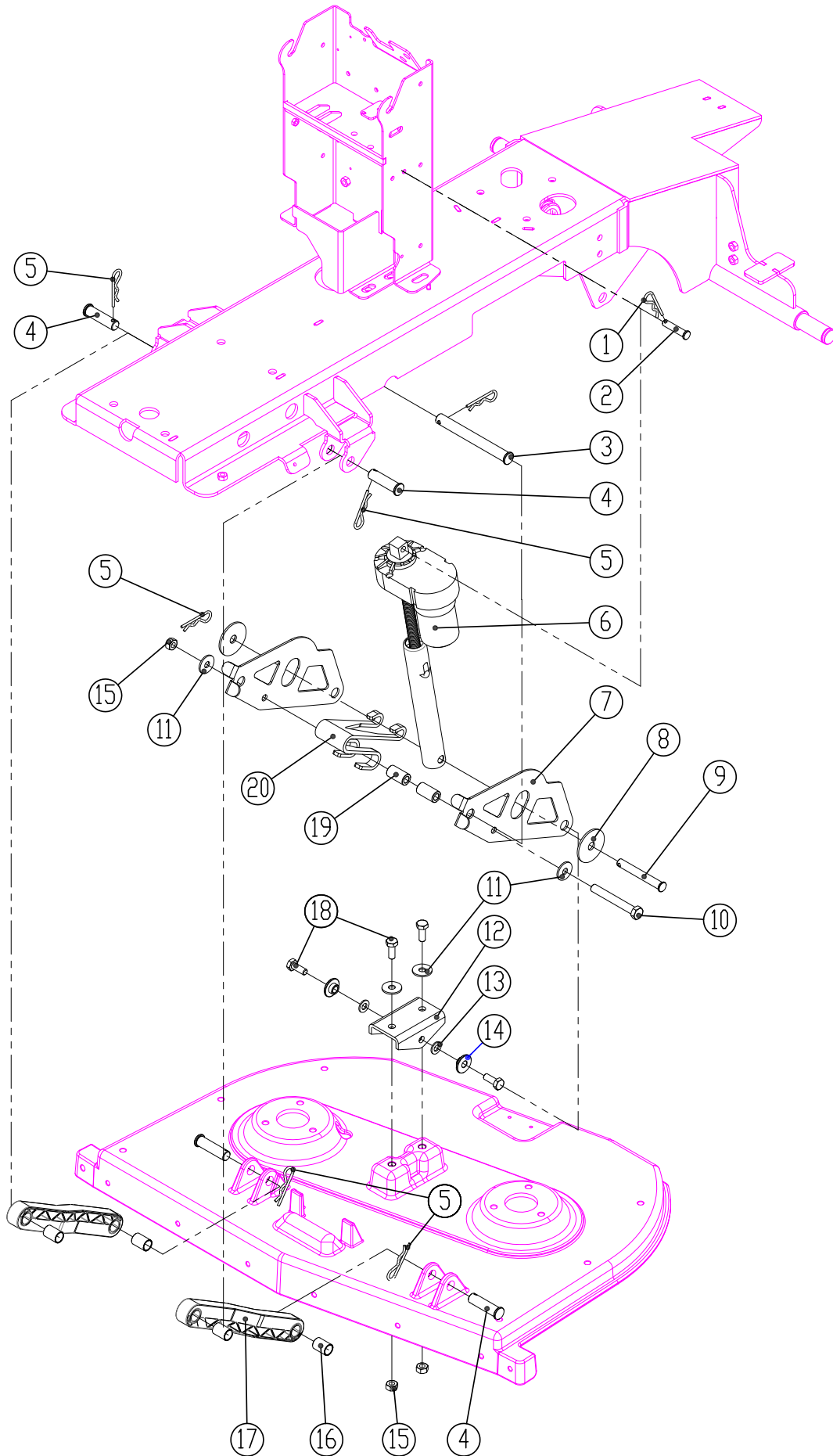



## PARTS LIST

### SCRUB HEAD LIFTING GROUP

DIA NO.	PART NUMBER	DESCRIPTION	NO REQ'D
1	8310320	PIN, COTTER	1
2	8210301	PIN, $\phi 9.5 \times 38$	1
3	8310311	PIN, $\phi 16 \times 150$	1
4	8310312	PIN, $\phi 16 \times 57$	4
5	8210309	PIN, COTTER	6
6	8310303A	LINEAR ACTUATOR, KIT	1
7	8310305	PLATE, ARM, SCRUB HEAD LIFTING	2
8	8310314	FLAT WASHER, LARGE	2
9	8310313	PIN, $\phi 12 \times 90$	1
10	1032090	BOLT, HEX HEAD, M10 $\times$ 90	1
11	1421030	FLAT WASHER, M10 $\times$ $\phi 30 \times 2.5$	4
12	8310304	BRACKET, SCRUB HEAD LIFTING	1
13	1421020	FLAT WASHER, M10 $\times$ $\phi 20 \times 2$	2
14	8310307	BUSHING, FLANGE	2
15	1123012	LOCK NUT, M10	3
16	8310144	SLEEVE, $\phi 16 \times \phi 18.6 \times 25.4$	4
17	8310118	ARM, SCRUB HEAD LIFTING	2
18	1011025	BOLT, HEX HEAD, M10 $\times$ 25	4
19	8310306	SLEEVE, $\phi 10.5 \times \phi 18.5 \times 34$	2
20	8310308	SPRING	1

**SCRUB HEAD GROUP**

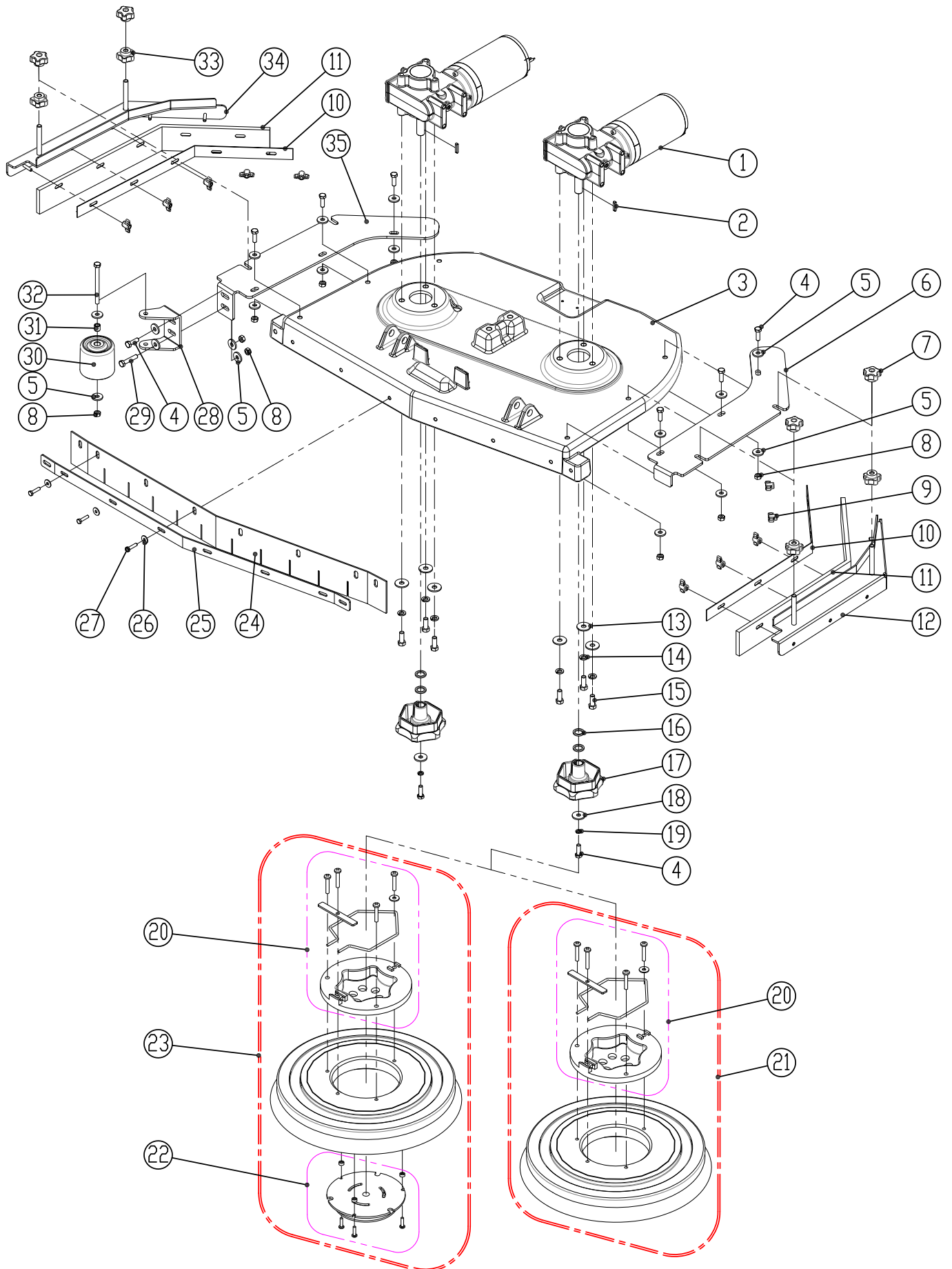

# PARTS LIST

## SCRUB HEAD GROUP

DIA NO.	PART NUMBER	DESCRIPTION	NO REQ'D
1	8310399	BRUSH MOTOR, 24VDC 450W, KIT	2
	8310316	CARBON BRUSH	4
2	1655025	KEY, 5×5×25	2
3	8311301	SCRUB HEAD HOUSING, RS26L	1
	8312301	SCRUB HEAD HOUSING, RS28L	1
	8310301	SCRUB HEAD HOUSING, RS32L	1
4	1021830	BOLT, HEX HEAD, M8×30	9
5	1421824	FLAT WASHER, M8× $\phi$ 24×2.0	18
6	8310356	BRACKET, LEFT	1
7	8210532	KNOB, M10	4
8	1123810	LOCK NUT, M8	9
9	8210531	KNOB, M6	10
10	8310355	CLAMP, SIDE SKIRT	2
11	8310365	BLADE, SIDE SKIRT, LINATEX	2
	8310366	BLADE, SIDE SKIRT, PU (OPTION)	2
12	8310357	BRACKET, SIDE SKIRT, LEFT	1
13	1421020	FLAT WASHER, M10× $\phi$ 20×2.0	6
14	1422010	LOCK NUT, 3/8	6
15	1023010	BOLT, HEX HEAD, 3/8-16×1	6
16	8210804	SPACER	4
17	8210805	HUB, BRUSH DRIVE	2
18	1421828	FLAT WASHER, M8× $\phi$ 28×3.0	2
19	1422821	LOCK WASHER, M8	2
20	9000004	CLUTCH, G-400S	2
21	9050013	BRUSH, 13 INCH, RS26L (OPTION)	2
	9050014	BRUSH, 14 INCH, RS28L (OPTION)	2
	9050016	BRUSH, 16 INCH, RS32L (OPTION)	2
22	9000003	CENTER LOCK, #3	2
23	9040013	PAD DRIVER, 13 INCH, RS26L	2
	9040014	PAD DRIVER, 14 INCH, RS28L	2
	9040016	PAD DRIVER, 16 INCH, RS32L	2
24	8311358	SKIRT, RS26L	1
	8312358	SKIRT, RS28L	1
	8310358	SKIRT, RS32L	1
25	8311359	CLAMP, SKIRT, RS26L	1
	8312359	CLAMP, SKIRT, RS28L	1
	8310359	CLAMP, SKIRT, RS32L	1
26	1421618	FLAT WASHER, M6× $\phi$ 18×1.6	7
27	1021616	BOLT, HEX HEAD, M6×16	7
28	8310361	BRACKET, PROTECTIVE WHEEL	1
29	1021840	BOLT, HEX HEAD, M8×40	1
30	8310362	PROTECTIVE WHEEL	1
31	8115404	SLEEVE, $\phi$ 8× $\phi$ 12.7×12.7	6
32	1022800	BOLT, HEX HEAD, M8×100	1
33	8310354	KNOB, M10	4
34	8310351	BRACKET, SIDE SKIRT, RIGHT	1
35	8310353	BRACKET, RIGHT	1

**SQUEEGEE GROUP**

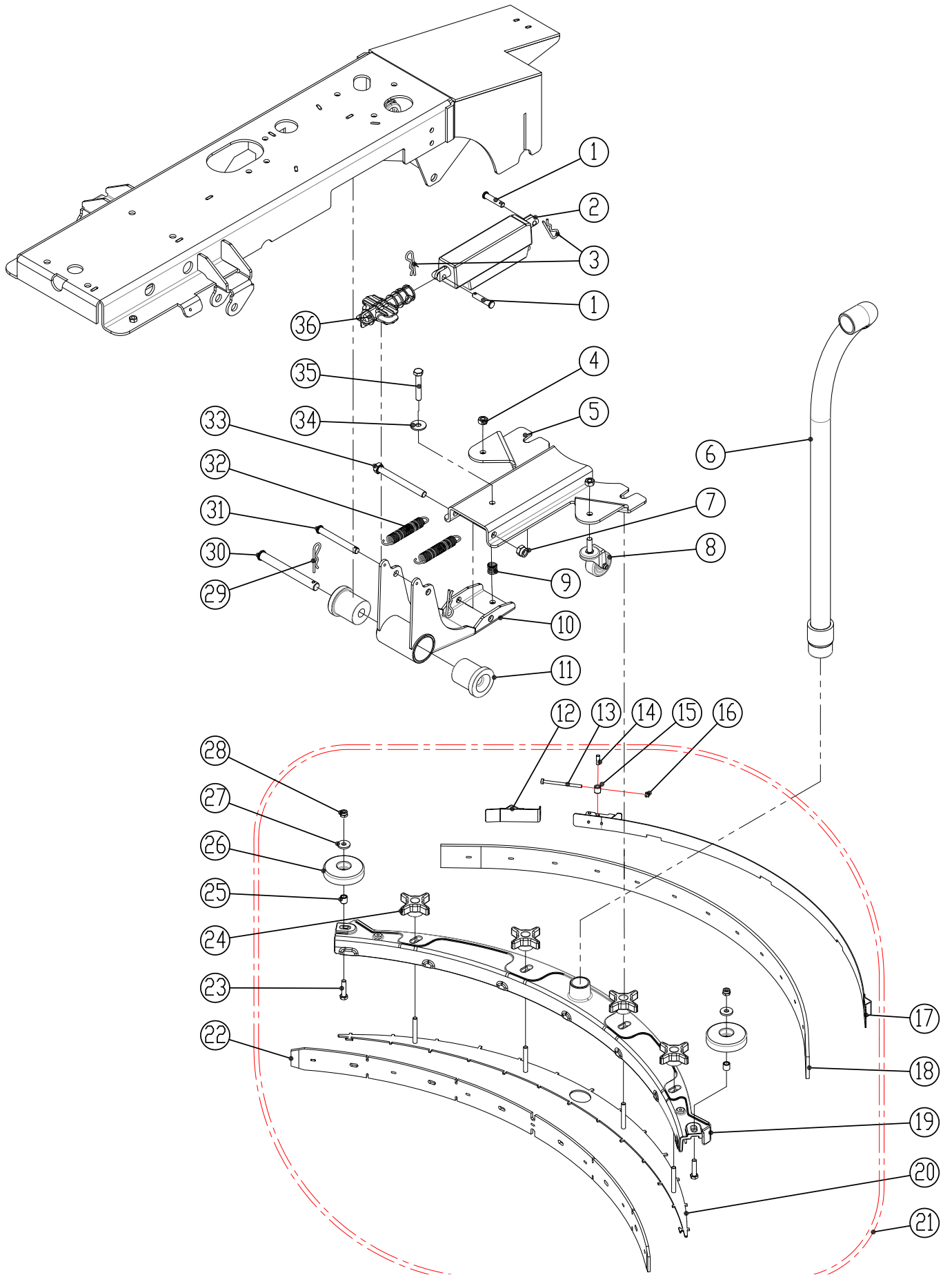

# PARTS LIST

## SQUEEGEE GROUP

DIA NO.	PART NUMBER	DESCRIPTION	NO REQ'D
1	8310506	PIN, $\phi$ 10×45	2
2	8310590A	LINEAR, ACTUATOR, KIT	1
3	8310320	PIN, COTTER	2
4	1121008	HEX NUT, M10	2
5	8310503	BRACKET, SQUEEGEE	1
6	8310240	VACUUM HOSE	1
7	1123115	LOCK NUT, M12	1
8	8310550	CASTER, 2 INCH	2
9	8310501	COMPRESSION SPRING,	1
10	8310504	ARM, SQGE LIFTING	1
11	8310505	FLEX BUSHING, TPU	2
12	8210525	SHORT CLAMP ASSEMBLY	1
13	1221575	SCREW, PAN HEAD, M5×75	1
14	8118624	SHAFT	1
15	8118623	SPACER	1
16	1123507	LOCK NUT, M5	1
17	8311514	CLAMP ASSEMBLY, RS26L	1
	8310514	CLAMP ASSEMBLY, RS28L / RS32L	1
18	8311531	REAR BLADE, LINATEX, RS26L	1
	8310531	REAR BLADE, LINATEX, RS28L/ RS32L	1
	8311541	REAR BLADE, PU, RS26L, OPTION	1
	8310541	REAR BLADE, PU, RS28L/RS32L, OPTION	1
19	8311561	SQUEEGEE HOSING, RS26L	1
	8310561	SQUEEGEE HOSING, RS28L / RS32L	1
20	8311562	RETAINER, SQUEEGEE, RS26L	1
	8310562	RETAINER, SQUEEGEE, RS28L / RS32L	1
21	8311560	SQUEEGEE ASSEMBLY, RS26L	1
	8310560	SQUEEGEE ASSEMBLY, RS28L / RS32L	1
22	8311534	FRONT BLADE, LINATEX, RS26L	1
	8310534	FRONT BLADE, LINATEX, RS28L / RS32L	1
	8311544	FRONT BLADE, PU, RS26L, OPTION	1
	8310544	FRONT BLADE, PU, RS28L/ RS32L, OPTION	1
23	1021835	BOLT, HEX HEAD, M8×35	2
24	8210518	KNOB, M8	4
25	8115404	SLEEVE, $\phi$ 8× $\phi$ 12.7×12.7	2
26	8116009	PROTECTIVE WHEEL	2
27	1421824	FLAT WASHER, M8× $\phi$ 24×2	4
28	1123810	LOCK NUT, M8	2
29	8210309	PIN, COTTER	2
30	8310311	PIN, $\phi$ 16×150	1
31	8310508	PIN, $\phi$ 12×100	1
32	8310509	EXTENSION SPRING	2
33	1031212	BOLT, HEX HEAD, M12×120	1
34	1421030	FLAT WASHER, M10× $\phi$ 30×2.5	1
35	1021060	BOLT, HEX HEAD, M10×60	1
36	8310507	ADAPTER	1



## **PARTS LIST**

### **SOLUTION & DETERGENT SYSTEM**

<b>DIA NO.</b>	<b>PART NUMBER</b>	<b>DESCRIPTION</b>	<b>NO REQ'D</b>
1	8310124	ELBOW, G1/2	1
2	1962025	CLAMP 16-25MM	8
3	8310901	TUBING, ID=16MM L=500MM	1
4	8310375	ELBOW, CHEMICAL CONNECTOR	1
5	8310371	SOLENOID VALVE, 24VDC	1
6	1421510	FLAT WASHER, M5× $\phi$ 10×1.0	2
7	1422513	LOCK WASHER M5	2
8	1221512	SCREW, PAN HEAD, M5×12	2
9	8310902	TUBING, ID=16MM L=40MM	1
10	8310903	TUBING, ID=12MM L=175MM	1
11	8310374	FITTING, PLASTIC	1
12	8310904	TUBING, ID=12MM L=210MM	1
13	8310905	TUBING, ID=4MM L=330MM	3
14	8310930A	DETERGENT PUMP, KIT	1
15	1914080	TIE, 3×80MM	19
16	8310910	TUBING, ID=4MM L=100MM	3
17	8310467	FITTING	7
18	8310909	TUBING, ID=4MM L=30MM	4
19	8310466	ONE WAY VALVE	1

**WEAR AND TEAR PARTS / 易损件清单****WEAR AND TEAR PARTS / 易损件清单**

<b>DIA NO.</b>	<b>PART NUMBER</b>	<b>DESCRIPTION</b>	<b>NO REQ'D</b>
1	8310119	10" WHEEL, PU TIRE	2
2	8116009	PROTECTIVE WHEEL	2
3	8310362	PROTECTIVE WHEEL	1
4	8311531	REAR BLADE, LINATEX, RS26L	1
	8310531	REAR BLADE, LINATEX, RS28L / RS32L	1
5	8311534	FRONT BLADE, LINATEX, RS26L	1
	8310534	FRONT BLADE, LINATEX, RS28L / RS32L	1
6	9050013	BRUSH, 13 INCH, RS26L	2
	9050014	BRUSH, 14 INCH, RS28L	2
	9050016	BRUSH, 16 INCH, RS32L	2
7	9040013	PAD DRIVER, 13 INCH, RS26L	2
	9040014	PAD DRIVER, 14 INCH, RS28L	2
	9040016	PAD DRIVER, 16 INCH, RS32L	2



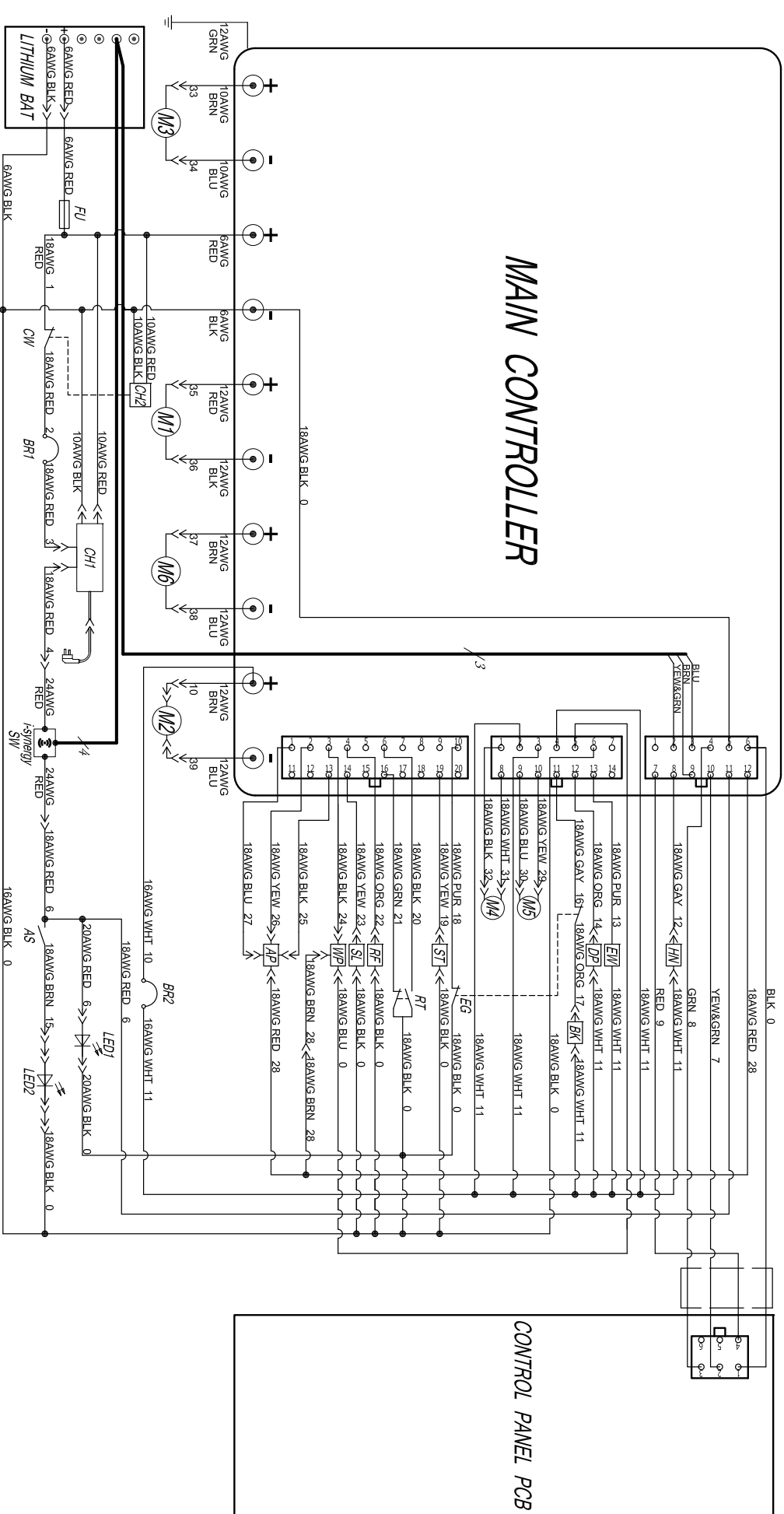

- LITHIUM BAT: Lithium-ion batteries
- FU: 150A fuse
- CW: Off-board charger interlock switch
- BR1: Main controller circuit breaker, 5A
- i-synergy SW: i-synergy starting up switch
- AS: Alarm lamp switch
- LED2: Alarm lamp
- CH1: On-board battery charger
- CH2: Off-board battery charger port

- LED1: Work LED light
- BR2: Brake circuit breaker, 10A
- M3: Traction motor
- M1: Brush motor, left
- M6: Brush motor, right
- M2: Vacuum motor
- AP: Accelerator Pedal, sensor
- WP: Proximity sensor
- SL: Solution tank water level sensor

- RF: Recovery tank water level sensor
- RT: Reverse switch
- ST: Seat switch
- EG: Emergency stop switch
- M4: Scrub head lifting actuator
- M5: Squeegee lifting actuator
- BK: Brake coil
- DP: Detergent pump
- EW: Solution solenoid valve
- HN: Horn