



[www.icecompanies.com](http://www.icecompanies.com)

Operator & Parts Manual

Self\_Contained Extractor



**iE410**

6210149U  
REV.06(07-2017)

**INTELLIGENT CLEANING EQUIPMENT**

---

## TABLE OF CONTENTS

SAFETY PRECAUTION . . . . .	2
MACHINE SET-UP . . . . .	3
MACHINE OPERATION . . . . .	3-4
MACHINE MAINTENANCE & STORAGE . . . . .	5
TROUBLESHOOTING . . . . .	6
MACHINE COMPONENTS . . . . .	7
PARTS LIST . . . . .	8-19
SPECIFICATIONS . . . . .	20
WIRING DIAGRAM . . . . .	21
WEAR & TEAR PARTS . . . . .	22

## SAFETY PRECAUTION



Carefully read and understand this manual before operating this machine.  
This machine must be grounded!

This machine shall be grounded while in use to protect the operator from electric shock. Grounding provides a path of least resistance for electric current. This machine is equipped with a cord having an equipment-grounding conductor and grounding plug. The plug must be plugged into an appropriate outlet that is properly installed and grounded in accordance with all local codes and ordinances. Do not remove the ground pin under any circumstances.

This machine is for use on a nominal 120-volt circuit and has a grounding plug that resembles the plug illustrated in Figure. Make sure that the machine is connected to an outlet having the same configuration as the plug. No adapter should be used with this machine.

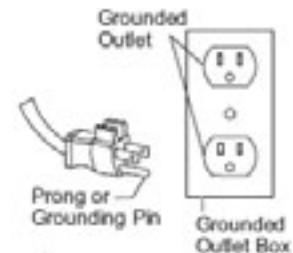

This machine is intended for commercial use. It is constructed for use in an indoor environment and is not intended for any other use. Use only recommended accessories.

1. Do not operate machine:

- Unless trained and authorized.
- In flammable or explosive areas.
- With a damaged cord or plug
- If not in proper operating condition.
- Unless you have read and understand the operators manual.
- With the use of extension cords.
- In outdoor areas and standing water.

2. Before operating machine:

- Make sure all safety devices are in place and operating properly.

3. When using machine:

- Do not run machine over cord.
- Do not pull cord around sharp edges or corners.
- Do not handle plug with wet hands.
- Report machine damage or faulty operation immediately.
- Do not pull machine by cord or plug.
- Do not unplug by pulling on the cord.
- Do not stretch cord.
- Keep cord away from heated surfaces.

4. Before leaving or servicing machine:

- Turn off machine.
- Unplug cord from outlet.

5. When servicing machine:

- Unplug cord from outlet.
- Use manufacturer supplied or approved replacement parts.



To avoid electrical shock, please replace the power cord immediately if any damage is being detected. The replacement must be performed only by an authorized person or by our customer service center.

## SELF-CONTAINED EXTRACTOR SET-UP



**Read operators manual thoroughly prior to operating or servicing this machine!!!**

Carefully check the shipping carton for signs of damage. Report any carton damage to carrier immediately.

Check carton contents to ensure carton is complete. Contact your ICE distributor if anything is missing.

Contents:

- Carpet Extractor
- 50' extension power cable



**Read operators manual thoroughly prior to operating or servicing this machine!!!**

1. Using a hose or bucket, fill tank with a maximum of 10 gallons of hot water.
2. Add distributor recommended cleaning solution.



**Do not use flammable liquids or operate machine in or near flammable liquids or vapors!!!**

3. Connect the supplied extension power cable to the machine. Plug cord into a grounded wall outlet. (see grounding instructions)
4. Drop the brush head to the floor with the foot release pedal on the back of the machine.

## MACHINE OPERATION

### PRIOR TO EXTRACTING CARPETS

1. Inspect power cable and extension cable for damage. Replace cable if damage is found.
2. Vacuum carpet to remove debris prior to extracting carpet.

### CARPET EXTRACTING

1. Turn on vacuum / pump switch.

*NOTE: Solution will only spray when the brush / spray button is pushed.*

2. To start cleaning, push the brush / spray button and begin to pull the machine backwards.

*NOTE: For best cleaning results, pull back on the machine at a pace of approx. 10 feet in 15 seconds.*

3. Release brush / spray button at the end of the path, and continue to pull machine back for another 12 inches to pick up excess solution.
4. Tip machine back onto the transport wheels and push forward to begin next path.
5. During pickup, the float shut-off will automatically prevent water from entering the recovery tank once the recovery tank is full.

*NOTE:* If foam develops in the recovery tank during vacuuming, use de-foamer chemical to help eliminate the foam. Foam will not activate the float shut-off, and therefore, may cause vacuum motor damage.

## **OPERATING HINTS**

1. Overlap cleaning path by approx. 2 inches
2. Work away from power outlet and power cable in order to avoid damage to the power cable.
3. Continually check for foam buildup in recovery tank. Use a distributor recommended foam control solution.

*NOTE:* Excessive foam buildup will not activate the float shut-off and may cause damage to the vacuum motor.

4. Repeat extraction path on heavily soiled areas.
5. If brush stops spinning, there may be an obstruction in the brush. Unplug the power cable, raise the brush off the floor and check for an obstruction. Check & reset the brush circuit breaker located on the control housing.
6. When recover of the dirty solution ends, or the solution tank is empty, you must drain the recovery tank. (see TANK DRAINING)

## **USE OF ACCESSORY TOOLS**

*NOTE:* Prior to cleaning upholstery, be sure to read cleaning instructions provided by the manufacturer.

1. Disconnect black vacuum hose off the back right side of the machine. Connect accessory vacuum hose to area where the standard vacuum hose was removed.
2. Connect accessory solution hose to brass quick connect coupler located on the back of the machine.
3. Connect accessory tool to solution and vacuum hoses.
4. Turn on vacuum / pump switch.
5. Operate accessory tools as needed.
6. When cleaning is completed, relieve water pressure from solution lines by turning off vacuum / pump switch and then squeeze trigger for 4 seconds.

## **DRAINING TANKS**

### **DRAINING SOLUTION TANK**

1. To drain any remaining water from the solution tank, pull the solution tank level hose off the hose fitting.
2. Drain dirty solution into floor drain.
3. Reattach the hose to the hose fitting.

### **DRAINING RECOVERY TANK**

1. Turn off machine, unplug and remove power cable.
2. Unhook drain hose off the back of the machine and remove drain hose stopper.
3. Drain dirty solution into floor drain.
4. Replace drain hose stopper and reattach hose to back of machine.

## MACHINE MAINTENANCE

To keep the machine performing well for many years, please follow the following maintenance procedures.



*Always confirm that the machine is unplugged prior to performing any maintenance or repairs!!!*

### DAILY MAINTENANCE

1. When cleaning operation is complete for the day, drain and rinse the recovery tank thoroughly with clean water.
2. Remove remaining solution from solution tank.
3. Remove float shut-off (ping pong ball in cage) from recovery tank and clean with water.
4. Remove and inspect spray jets. If necessary, clean jets in acetic acid solution.



*Do not clean brass jets with a pointed object, as it will damage the jets.*

5. Check brush assembly & remove any debris or carpet fibers.
6. Check pick up head and remove any debris or carpet fibers.
7. Check condition of the stainless steel pickup shoes on the pickup head. The shoes must contact the floor for the whole length of the pickup head. Replace as necessary.
8. Clean machine with a nonabrasive cleaner.
9. Inspect power cable for any damage. Replace if necessary.

### MONTHLY MAINTENANCE

1. Flush pump & plumbing with an acetic acid solution to dissolve any chemical buildup.

#### *Mixing Instructions:*

- a) Premix 16 oz. or an acetic acid solution with 2 gallons of water and pour into solution tank.
  - b) Turn vacuum / pump switch on
  - c) Put machine head over floor drain and operate machine for 50 seconds.
  - d) Shut machine down and allow remaining solution to sit in machine overnight.
  - e) The following day, spray out remaining solution and flush system again with 3 gallons of clean water.
- 2) Inspect machine for water leaks.
  - 3) Lubricate wheels with a water resistance lubricant.

### MACHINE STORAGE

1. Prior to storing the machine, ensure the solution and recovery tanks are clean and empty of any solution.
2. Store machine in upright position in a dry area, with the brush head off the floor.
3. Remove recovery tank clear lid to allow for air circulation.



*If you are storing the machine in an area which can freeze, be sure both tanks and the solution plumbing are empty of all water and dry!*

## BASIC TROUBLESHOOTING

PROBLEM	CAUSE	SOLUTION
Machine doesn't work	Not plugged in to power source	Plug into a grounded outlet
	Faulty power cable	Contact ICE Distributor
	Faulty extension power cable	Replace with new extension power cable
	Building circuit breaker tripped	Reset circuit breaker
Solution pump not working	Vacuum / pump switch not on	Turn on switch
	Vacuum / pump switch faulty	Contact ICE Distributor
	Faulty solenoid	Contact ICE Distributor
	Faulty solution pump	Contact ICE Distributor
	Pump overheated	Determine cause and allow 30 minutes for pump to cool
	Loose or broken wiring	Contact ICE Distributor
Vacuum motor not working	Vacuum / pump switch not on	Turn on switch
	Vacuum / pump switch faulty	Contact ICE Distributor
	Vacuum motor thermal overload tripped	Check for obstruction and allow 30 minutes to cool
	Faulty vacuum motor	Contact ICE Distributor
	Worn carbon brushes	Contact ICE Distributor
	Loose or broken wiring	Contact ICE Distributor
Poor pick up	Air leaking around clear recovery lid	Ensure recovery lid is firmly tightened
	Clogged float shut-off	Remove float shut-off and clean off debris
	Float shut-off is activated	Drain recovery tank
	Loose drain hose stopper	Ensure stopper is securely in place
	Loose vacuum hose connections	Ensure vacuum hose connections are tight
	Defective vacuum hose	Replace vacuum hose
	Loose vacuum hose cuffs	Ensure cuffs are secure to the hose
	Damaged or loose pickup head shoes	Contact ICE Distributor
	Pulling machine too fast	Slow down cleaning operation
Uneven or no solution spray	Solution tank is empty or low	Fill solution tank
	Vacuum / pump switch not on	Turn on switch
	Dirty or plugged spray tips	Clean or replace spray tips
	Improper spray tip size or spray angle	Contact ICE Distributor
	Worn spray tips	Contact ICE Distributor
	Faulty solution pump	Contact ICE Distributor
	Plugged solution tank filter	Clean or replace filter
	Pinched or kinked solution hose	Check for obstructions and kinks and reroute or replace if needed

## MACHINE COMPONENTS

1. Vacuum/Pump ON/OFF switch
2. Brush circuit breaker
3. Brush/spray ON/OFF switch
4. Drain hose
5. Accessory tool solution hookup
6. Brush raise and lower foot pedal
7. Spray jets
8. Brush assembly
9. Pickup head
10. Solution tank fill port
11. Clear dome





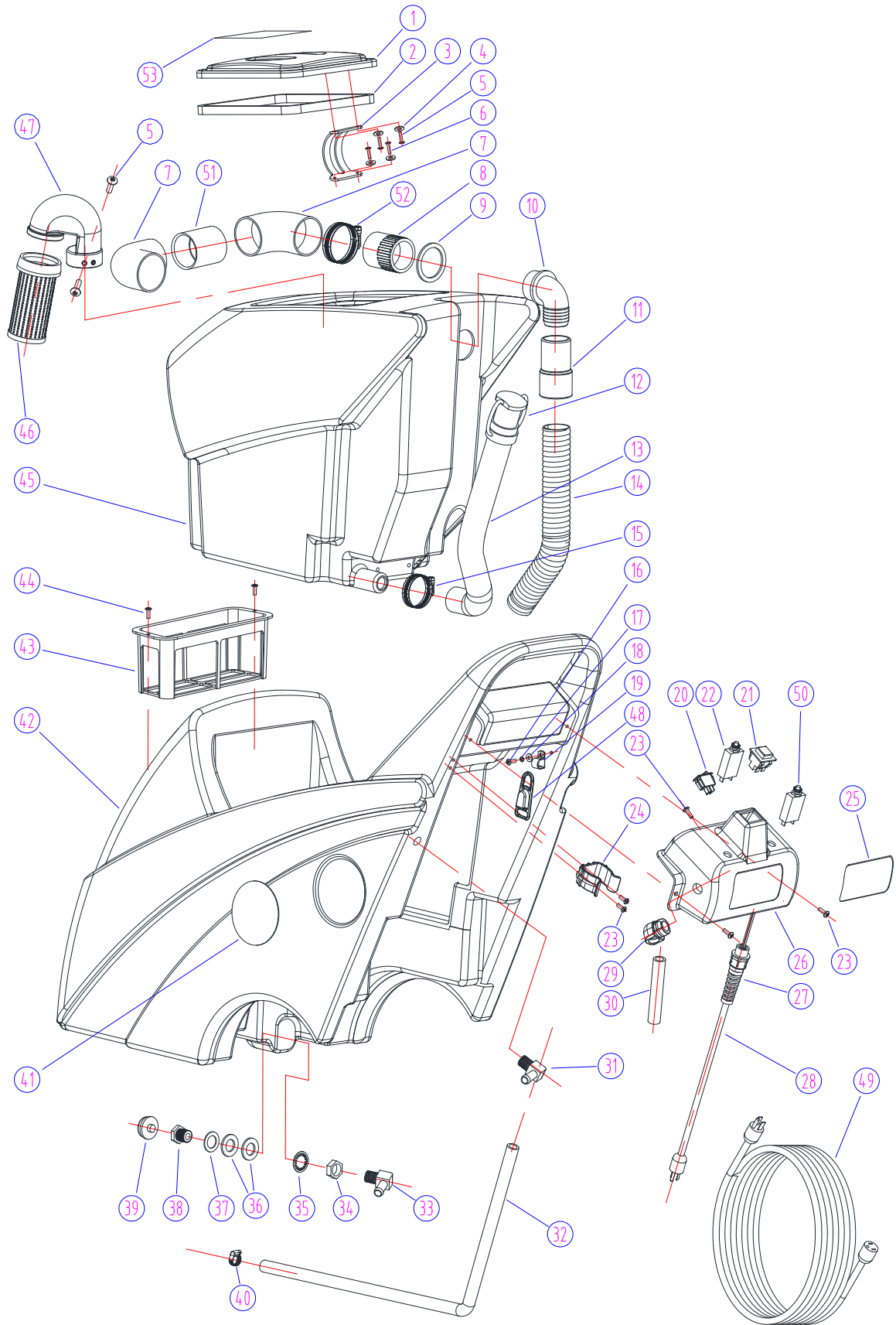

## PARTS LIST

DIA NO	PART NUMBER	DESCRIPTION	NO REQ'D
1	2320216	Clear Dome	1
2	2320218	Gasket,Clear Dome	1
3	2320217	Rubber Hinge	1
4	1421409	Washer,Plain, $\Phi$ 4.3X $\Phi$ 9X0.8	4
5	1321210	Screw, Ph, St4 X10	4
6	1221410	Screw, Ph, M4 X10	2
7	6210109	Bend, Tube	2
8	6210104	Coupler	1
9	6210103	Gasket,Coupler	1
10	6210108	Elbow	1
11	6210114	Coupler,Vac Hose	1
12	2230131	Plug, Serial number:000000-001234	1
13	6210705	Drain Hose, Serial number:000000-001234	1
	8011030	Drain Hose,Serial number:001235-	1
14	6210113	Vac Hose	1
15	1962050	Clamp, Hose 2"	1
16	1021610	Screw, Hex, M6X10,SST	1
17	1422616	Washer, Lock, SST, $\Phi$ 6	1
18	1421617	Washer, Plain, $\Phi$ 6X $\Phi$ 16X2	1
19	6150712	Clamp, Cord	1
20	6210503	Rocker Switch	1
21	6210502	Push Button Switch	1
22	6210504	Circuit Breaker, 2A	1
23	1221512	Screw, M5X12, PH	3
24	6210111	Clamp, Drain Hose	1
25	6210125	Warning Decal	1
26	6210501	Switch Housing	1
27	4020310	Strain Relief	1
28	6210518	Power Cord	1
29	6210505	Elbow Corrugated Tubing Fitting	1
30	6210506	Corrugated Tubing	1
31	6210136	Barb, Right Angle	1
32	6210135	Tubing	1
33	6180163	Barb, Hose	1
34	6180126	Nut, Coupling	1
35	6120667	Washer, Lock, Internal Tooth	1
36	6160509	Gasket, Solution, Intake	2
37	6120276	Washer, Plain	1
38	6180125	Coupling	1
39	6110411	Strainer, Line	1

**PARTS LIST**

<b>DIA NO</b>	<b>PART NUMBER</b>	<b>DESCRIPTION</b>	<b>NO REQ'D</b>
40	1962025	Clamp(16-25)	1
41	4010316	Logo	3
42	6210101	Solution Tank	1
43	6210107	Filter	1
44	1321310	Screw, ST4.8X9.5	2
45	6210102	Recovery Tank	1
46	8111015	Float, Shut-off	1
47	2320220	Bend	1
48	8014043	Cord Wrap	1
49	6210519U	Power Cord	1
50	6210508	Circuit Breaker, 17A	1
51	6210112	Coupler	1
52	1962053	Clamp(40-64)	1
53	2320415	Warning Decal	1

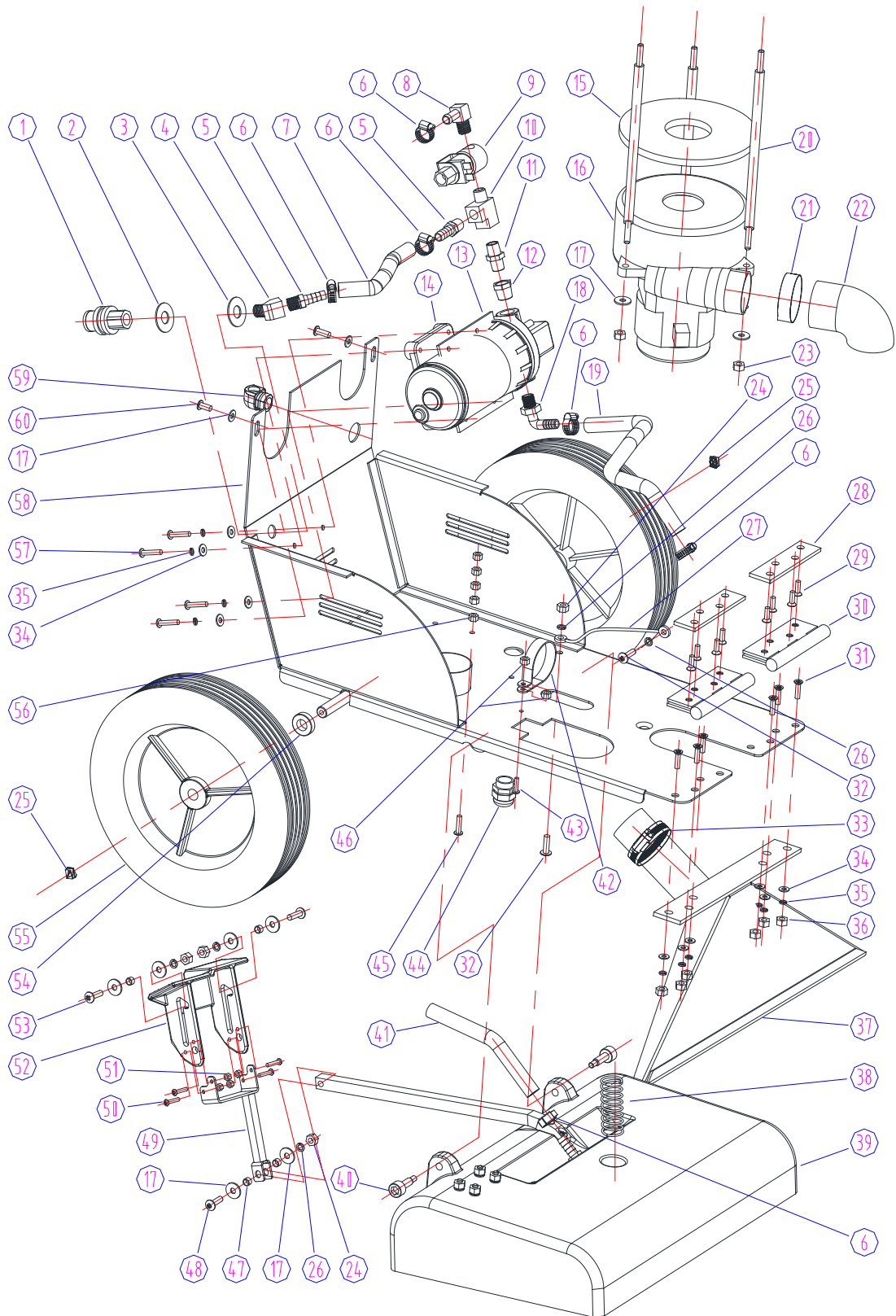

## PARTS LIST

DIA NO	PART NUMBER	DESCRIPTION	NO REQ'D
1	6180208	Coupler, Quick Connect	1
2	1421432	Washer, Plain ,Ø13.5XØ32X1.5	1
3	1421428	Washer, Plain ,Ø14XØ32X1.5	1
4	6180115	Elbow, Street, 45°	1
5	6180128	Barb, Hose	2
6	1962016	Clamp, Hose 3/8"	6
7	6210116	Hose, High Pressure	1
8	6210607	Barb,Pump	1
9	6210604U	Solution Solenoid, 120V/60HZ	1
10	6210606	Connector, Three-way	1
11	6210603	Connector	1
12	6210602	Barb, Pump	1
13	6210601	Mounting Frame, Pump	1
14	6150195	Pump, 115V, 100PSI	1
15	2310116	Gasket, Vac Motor	1
16	2310135A	Vac Motor, 3-STAGE 120V (With terminal)	1
17	1421617	Washer, SST, Plain, Ø6XØ16X2	11
18	6180210	Bend, Nylon, Pump	1
19	6210117	Hose, Solution	1
20	2310122	Stud	3
21	1914300	Tie, Cable	1
22	2320208	Acoustic Insulation Pipe	1
23	1123608	Nut, Lock, SS, M6	3
24	1121605	Nut, SST, M6	4
25	6110011	Cap, Axle	2
26	1422616	Washer, Lock, Ø6	5
27	8111020	Cable	1
28	6210105	Spacer	2
29	1222515	Screw, FH, M5X15, SST	8
30	6160406	Hinger, SST 4"	2
31	1222520	Screw, FH, SST, M5X20	6
32	1221616	Screw, SST, PH, M6X16	2
33	1962050	Clamp, Hose 2"	1
34	1421515	Washer, SST, PLAIN, Ø5XØ15X1	10
35	1422513	Washer, Lock, Ø5	10
36	1121505	Nut, SST, M5	6
37	6210140	Carpet Pick-up Tool	1
38	6210407	Spring	1
39	6210400U	Mounting Base Assy, Brush	1

## PARTS LIST

DIA NO	PART NUMBER	DESCRIPTION	NO REQ'D
40	6210110	Shoulder Screw	2
41	6210115	Hose, Spraying	1
42	6210130	Clamp	1
43	1221416	Screw, RHM,M4X16,SST	1
44	2320403	Strainer	1
45	1221425	Screw, RHM,M4X25,SST	1
46	1123406	Nut, Nylon, Insert, M4	2
47	6210106	Spacer	4
48	1021640	Screw, M6X40,Hex	1
49	6210305	Bracket, Foot Step	1
50	1221515	Screw, RHM, M5X15, SST	4
51	1123507	Nut, Lock, SST, M5	4
52	2320209	Foot Step	1
53	1021625	Screw, RHM, M6X25, SST	2
54	6160113	Washer, Wheel, AL	2
55	2320228	Wheel, 10"	2
56	1113304	Kep nuts, M4	5
57	1221530	Screw,RHM,M5X30,SST	4
58	6210200	Bottom Plate Assy	1
59	6210505	Elbow Corrugated Tubing Fitting	1
60	1221616	Screw,SST,PH,M6X16(NYLOCK)	2

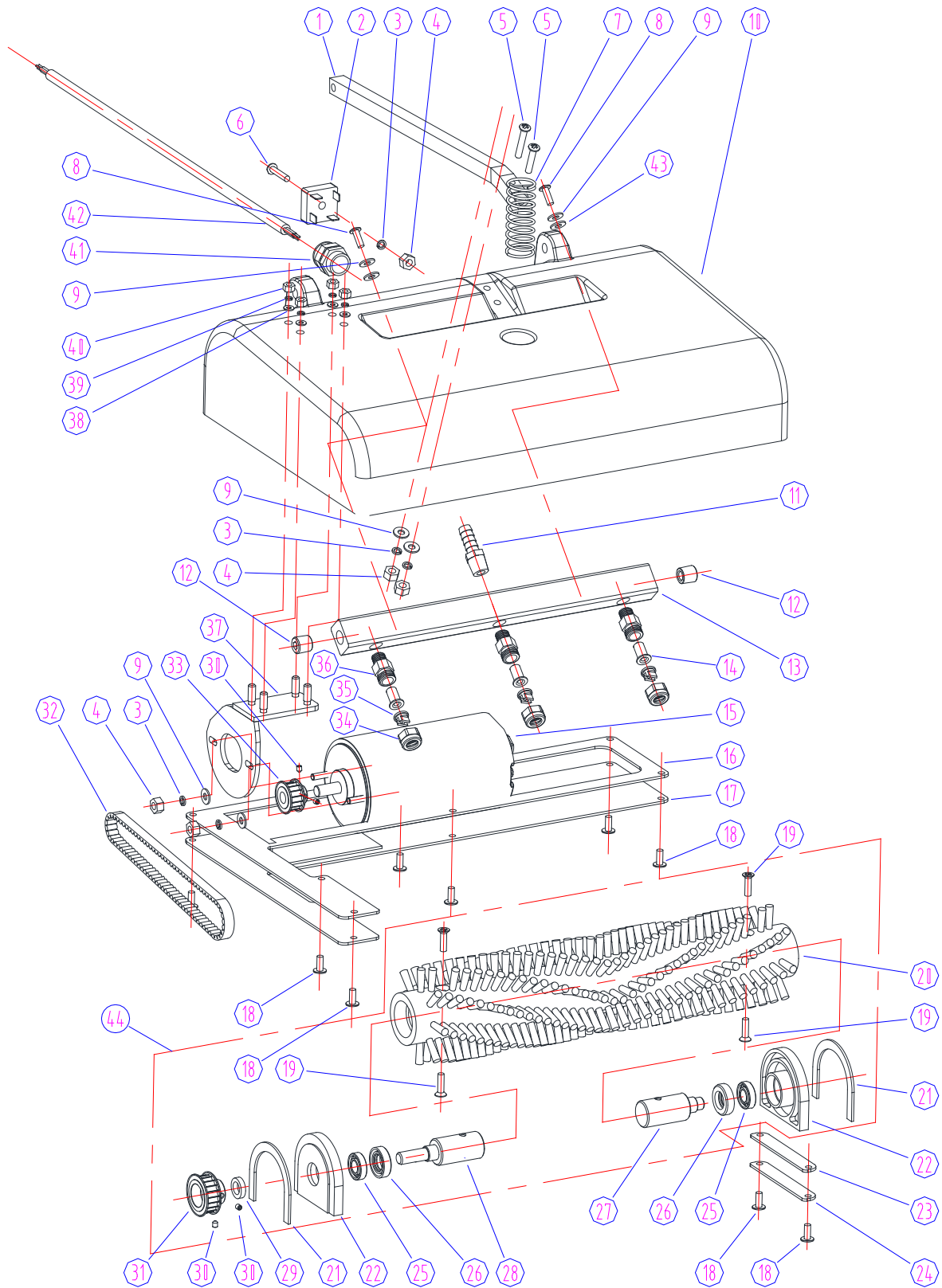

**PARTS LIST**

<b>DIA NO</b>	<b>PART NUMBER</b>	<b>DESCRIPTION</b>	<b>NO REQ'D</b>
1	6210403	Lift Bar	1
2	6210423	Rectifier	1
3	1422513	Washer Lock SST Ø5	5
4	1121505	Nut SST,M5	5
5	1221530	Screw SST PH M5X30	2
6	1221525	Screw, PH,SST,M5X25	1
7	6210407	Spring	1
8	1221514	Screw PH SST M5X14	2
9	1421515	Washer PLAIN Ø5XØ15X1	6
10	6210401	Mounting Base Brush	1
11	6180128	Barb Hose	1
12	6140330	Insert Sprayer Body	2
13	6210421	Sprayer Body	1
14	6110421	Strainer	3
15	6210435U	Motor, 120V	1
16	6210433	Gasket	1
17	6210431	Bottom Plate	1
18	1221512	Screw BH M5X12 SST	10
19	1513520	Screw FH SST M5X20	4
20	6210412	Brush	1
21	6210417	Gasket	2
22	6210414	Frame Brush	2
23	6210406	Gasket	1
24	6210404	Plate	1
25	1611629	Bearing	2
26	1632512	Seal	2
27	6210411	Shaft Brush	1
28	6210413	Axle Pulley	1
29	6210416	Spacer	1
30	1521408	Screw Hex Socket	4
31	6210415	Driven Pulley	1
32	6210402	Belt	1
33	6210432	Driving Pulley	1
34	6210426	Caps, Nozzle Bodies	3
35	6180574	Tip-Nozzle, Spray,SST 110	3
36	6210425	Adapters	3
37	6210436	Mounting Bracket, Motor	1
38	1421617	Washer, SST, Plain, Ø6XØ16X1.5	4
39	1422616	Washer, Lock, Ø6	4
40	1121605	Nut, SST, M6	7
41	2320403	Strain Relief	1
42	6210408	Power Cord	1
43	6160515	Gasket	2
44	6210410	Brush Assembly	1



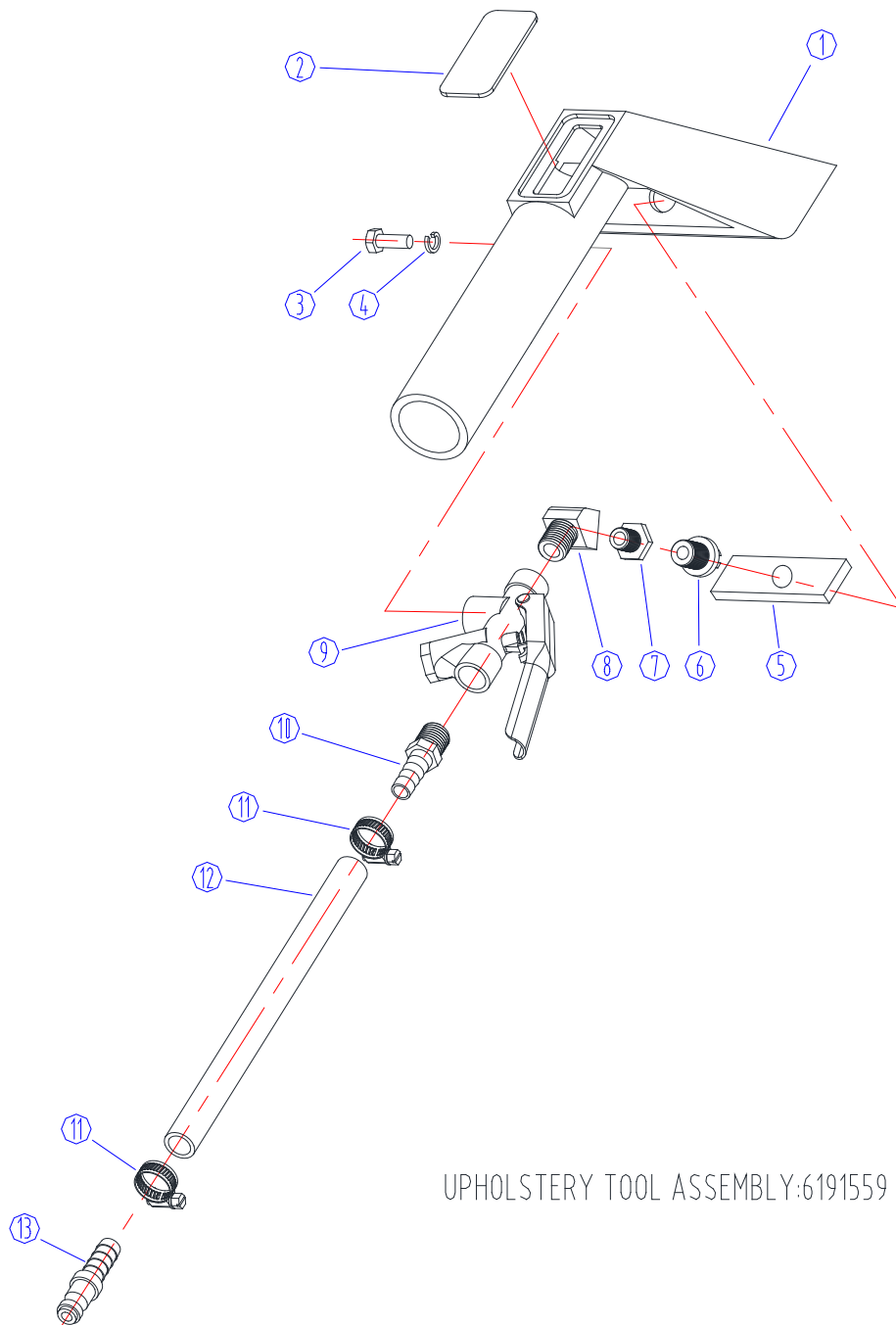

UPHOLSTERY TOOL ASSEMBLY:6191559

**PARTS LIST**

<b>DIA NO</b>	<b>PART NUMBER</b>	<b>DESCRIPTION</b>	<b>NO REQ'D</b>
1	6140328	Upholstery Tool	1
2	6140327	Window, Hand Tool	1
3	1023806	Screw, 5/16-18X5/8"L, HH	1
4	1421816	Washer, Plain, Ø8XØ16.5X1	1
5	6160531	Gasket	1
6	6180159	Nozzle, Spray Tip, 80°	1
7	6180105	Bushing, Brass	1
8	6180115	Elbow, Street, 45 Degrees	1
9	6110933	Trigger Valve	1
10	6180128	Barb, Hose	1
11	1962016	Clamp, Hose 3/8"	2
12	6185317	Solution Hose, 3/8"	1
13	6180241	Barb, Hose Mail Plug	1

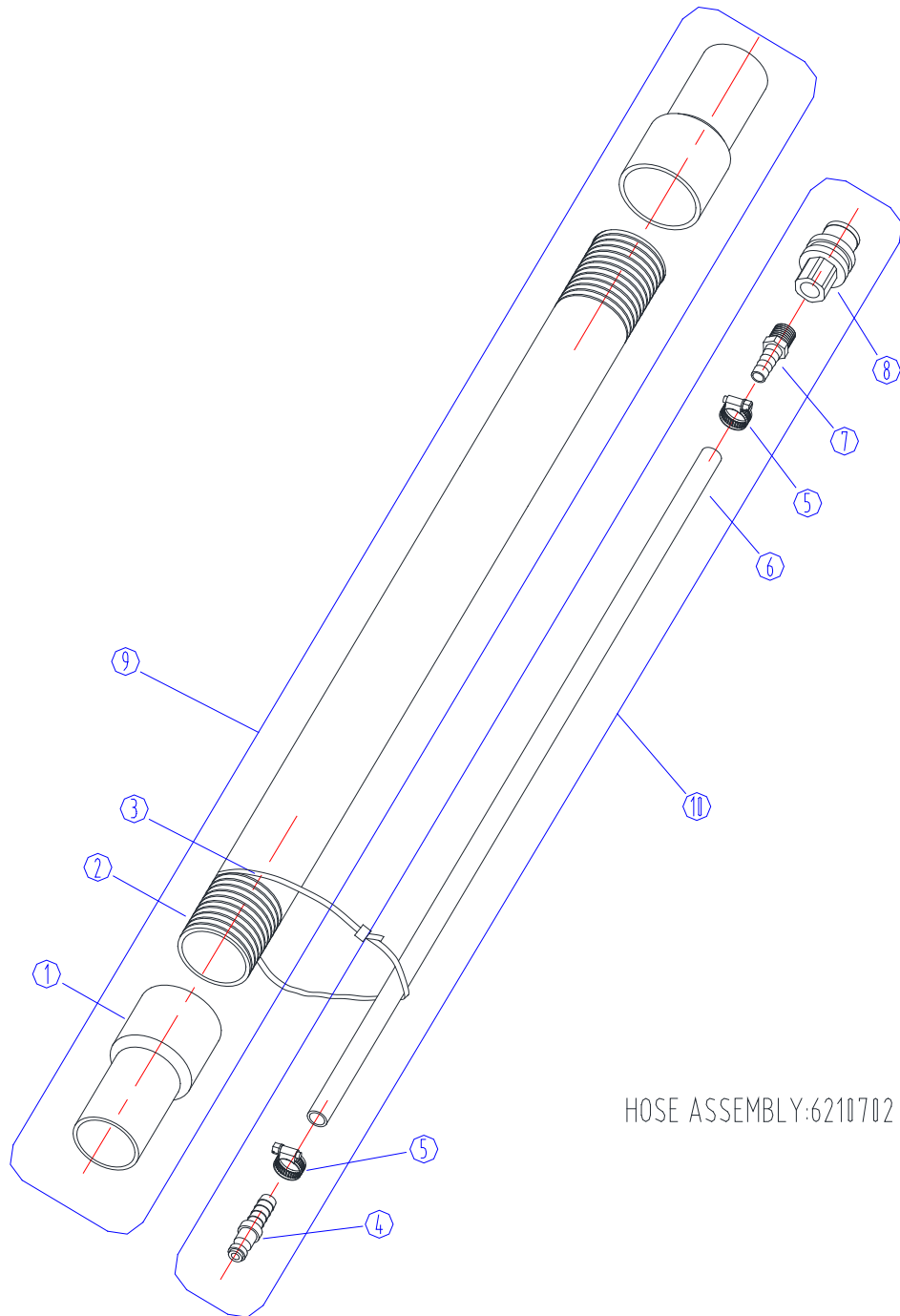

HOSE ASSEMBLY:6210702

**PARTS LIST**

<b>DIA NO</b>	<b>PART NUMBER</b>	<b>DESCRIPTION</b>	<b>NO REQ'D</b>
1	6160215	Cuff 1 1/2"	2
2	6210703	Hose, Vacuum	1
3	1914300	Tie, Cable	16
4	6180241	Hose Barb/Mail Plug, SST	1
5	1962016	Clamp, Hose, SST 3/8"	2
6	6210704	Hose, Solution, 16"L	1
7	6180128	Hose Barb	1
8	6180208	Couple, Quick Connect	1
9	6210703A	Vacuum Hose Assembly	1
10	6210704A	Solution Hose Assembly	1

TECHNICAL DATA	
Model	iE410
Voltage	120V
Power	1680W
Current	14A
Frequency	60Hz
Solution Capacitor	10Gallon
Recovery Capacitor	8Gallon
Vacuum Motor	1200W
Vacuum	3000mmH <sub>2</sub> O(120")
Flow rate	2940L/Min(100CFM)
Pump	100 P.S.I
Brush Motor	150W
Cleaning Path	16"(41CM)
RPM	1/5P 1400RPM
Length of Power cord	15M
Weight	43KG
Dimensions	92.9cm(L)X41.2cm(W)X89.5cm(H)

# Wiring Diagram

## iE410

### WIRING

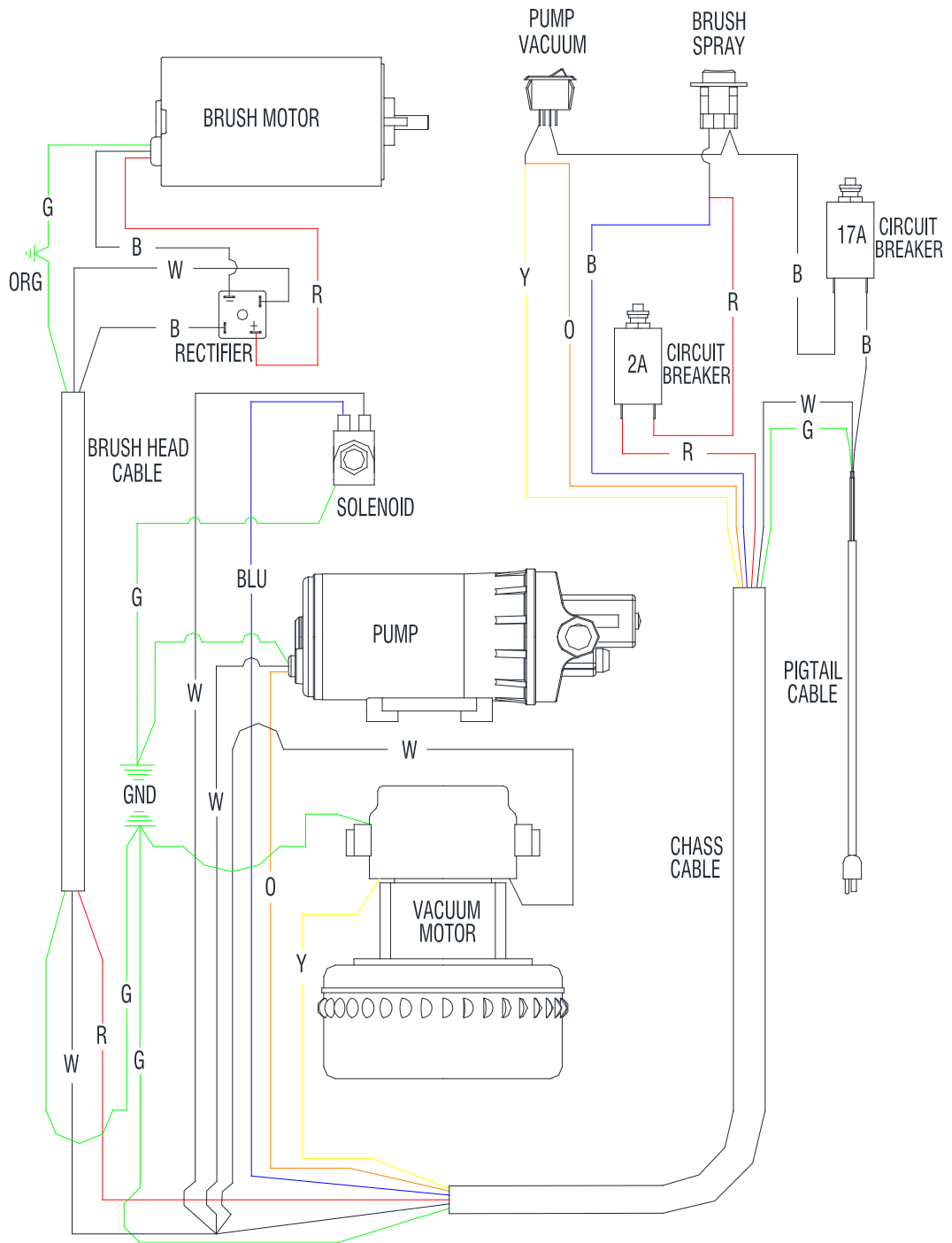

## WEAR &amp; TEAR PARTS

DIA NO	PART NUMBER	DESCRIPTION	NO REQ'D
1	2320228	Wheel, 10"	2
2	6210412	Brush	1
3	6210402	Belt	1

## CERTIFICATE OF QUALIFIED

MODEL : \_\_\_\_\_

SERIAL NO.: \_\_\_\_\_

INSPECTOR: \_\_\_\_\_

DATE : \_\_\_\_\_

**ICE Company Limited**

TEL : (+86) 769 8186 9000

FAX : (+86) 769 8186 3000